



P1F Pneumatic Cylinders

Ø32 to Ø125mm
According to ISO 15552

Catalog 0980



ENGINEERING YOUR SUCCESS.

Features - Product Overview 3-4

Ordering Information5

Technical Data..... 6-7

Size and Selection Guide 8-11

Dimensions 12-15

Accessories 16-24

Sensors 25-28

Seal Kits.....29

Air Quality Specification.....30

Offer of Sale31

⚠ WARNING

FAILURE OR IMPROPER SELECTION OR IMPROPER USE OF THE PRODUCTS AND/OR SYSTEMS DESCRIBED HEREIN OR RELATED ITEMS CAN CAUSE DEATH, PERSONAL INJURY AND PROPERTY DAMAGE.

This document and other information from Parker Hannifin Corporation, its subsidiaries and authorized distributors provide product and/or system options for further investigation by users having technical expertise. It is important that you analyze all aspects of your application including consequences of any failure, and review the information concerning the product or system in the current product catalog. Due to the variety of operating conditions and applications for these products or systems, the user, through its own analysis and testing, is solely responsible for making the final selection of the products and systems and assuring that all performance, safety and warning requirements of the application are met.

The products described herein, including without limitation, product features, specifications, designs, availability and pricing, are subject to change by Parker Hannifin Corporation and its subsidiaries at any time without notice.

Offer of Sale

The items described in this document are hereby offered for sale by Parker Hannifin Corporation, its subsidiaries or its authorized distributors. This offer and its acceptance are governed by the provisions stated on the separate page of this document entitled "Offer of Sale".



Standard Cylinders ISO 15552**Global product range**

The P1F Series meets the specifications of the ISO 15552 standard. This means full interchangeability to any ISO cylinder anywhere around the globe. P1F will be available throughout the extensive worldwide Parker Hannifin organization.

Features

- Smooth profile or tie-rods design
- Bore sizes 32 - 125 mm
- Corrosion resistant design with end plates and barrel in sandblast and anodized aluminum
- Magnetic piston standard
- Polyurethane seal technology inside
- Cushioning stainless steel screws on same side
- New adjustable pneumatic and mechanical cushioning system reduces the noise caused by the impact of the piston on the end covers (standard)
- Full range of mountings available
- Full range of 'drop-in' sensors available

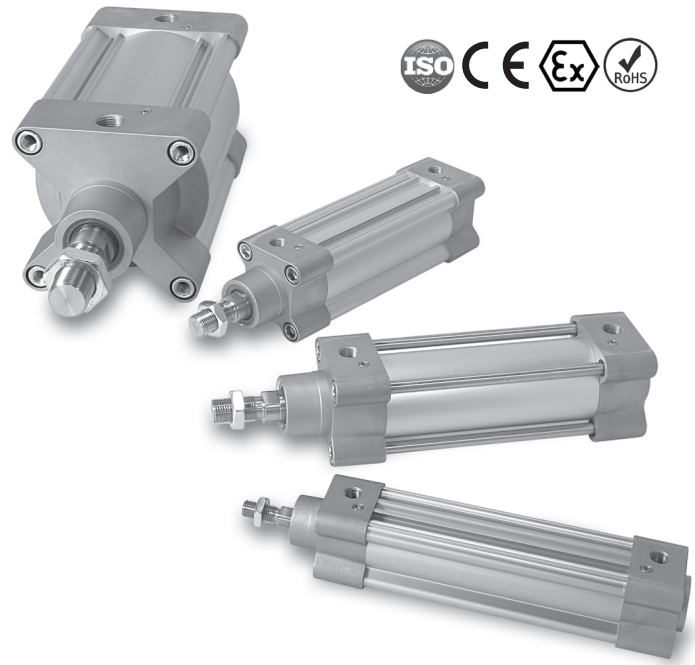
**Design Variants****Smooth profile - P1F-S, P1F-K**

The P1F in bore sizes $\varnothing 32$ to $\varnothing 125$ mm is a smooth profile designed cylinder with a magnetic piston used for standard temperature range from -20°C to $+80^{\circ}\text{C}$. Utilizing internal composite technology to save weight and reduce impact kinetic energy, while assuring the high performance and functionality expected for an ISO cylinder. Aluminum end covers, carbon steel piston rod guided with a PTFE coated steel bearing, pneumatic cushioning and polyurethane (PUR) seals as standard, this is our smooth profile industrial ISO cylinder.

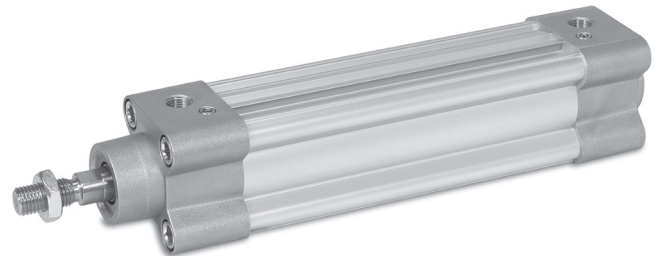

www.parker.com/pdn/P1F-S

Smooth profile - P1F-A

Similar to the smooth profile version but in an ATEX variant and a restricted temperature range from -20°C to $+60^{\circ}\text{C}$. Average speed up to 0.5 m/s and max. frequency 1Hz.

CE Ex II 2GD Ex h IIC T4 T=120°C GDb -20°C ≤ Ta ≤ +60°C

Tie-Rods round profile - P1F-T, P1F-N

Similar to the smooth profile version but in a Tie-Rods design for heavy duty applications. Round tube is made in anodized aluminum; Tie-Rods in stainless steel as a standard.

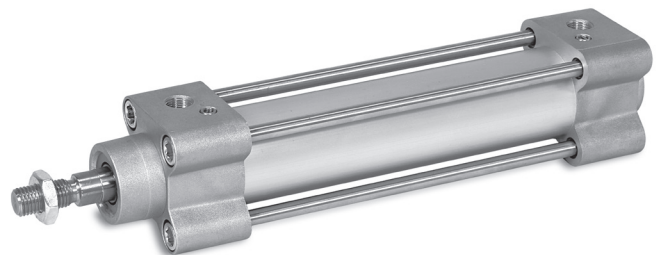

www.parker.com/pdn/P1F-T

Features

Smooth profile with rod locks - P1F-L

The rod lock incorporates a powerful piston rod locking device, which clamps the piston rod and locks it in position. The lock is spring activated and engages when air pressure is lost. The lock is integrated into the front (head) cover of the cylinder.

Tie Rod and Profile Pneumatic Cylinders P1F Series

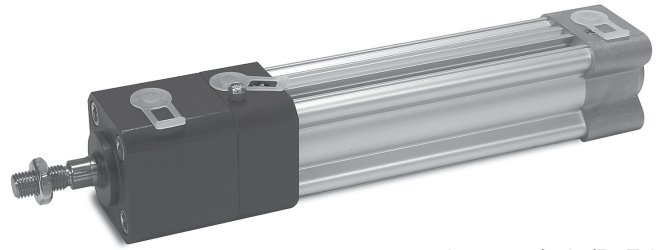

www.parker.com/pdn/P1F-L

Air Reservoirs - P1F-P

Air reservoirs are produced by a cylinder tube and two standard rear end plates and used, e.g. together with throttle valves to achieve a timer function in a pneumatic system. The delay of time will be varied by changing the throttle valve and by the size of the air reservoir. With a well functioning throttle valve and a suitable air reservoir it would be possible to achieve an accuracy of $\pm 5\%$. The reservoir is also used to equal pressure variants into system and to handling short extreme air consumptions without functional disorders. The air reservoirs could also be used together with check valves in order to retain a pressure which is essential for safety reasons.



Options

High temperature option

All seals in the high temperature version of P1F are developed and validated for continuous operation up to $+150^{\circ}\text{C}$. The combination of the seal geometry and the FKM (fluoro elastomers) material ensures reliable and long service life. High temperature cylinders have no magnetic piston and cannot be fitted with sensors (the magnetic field strength in high temperatures is too low to ensure correct reliable sensor function).

Low temperature option

All seals in the low temperature version of P1F are developed and validated for continuous operation down to -40°C . Ultrathane polyurethane TPU-PUR seal technology and specifically formulated grease support performance and reliability for low temperature applications. As standard supplied with a magnetic ring in the piston for proximity sensing.

Metallic scraper option

In environments where the piston rod may be coated with resin, ice, cement, sugar crystals, dough, etc., primarily in timber handling, refrigerated/chilled transport, cement industry, chemicals and food and drinks a metal scraper in combination with a hard-chromium plated piston rod is the right solution. Available for low temperature range applications from -30°C to $+80^{\circ}\text{C}$.

Ordering Information

Ordering Information

P1F	-	S	032	M	C	-	0160	-	0000
------------	---	----------	------------	----------	----------	---	-------------	---	-------------

Series	
P1F	Global ISO

Profile/cylinder design	
S	Smooth
K	Smooth with through rod
L	Smooth with dynamic rod lock ^{1,3}
T	Tie-Rods
N	Tie-Rods with through rod
P	Air reservoir ¹

Cylinder bore size	
032	32mm
040	40mm
050	50mm
063	63mm
080	80mm
100	100mm
125	125mm

Cylinder stroke	
....	Stroke length in mm (max. 2000)

Piston style	
-	Standard with magnet ⁴
F	Standard w/o magnet
X	Aluminum with magnet
A	Aluminum w/o magnet

Piston rod material male thread	
C	Chrome plated carbon steel
R	Chrome plated stainless steel (17-4)

Piston rod material female thread	
F	Chrome plated carbon steel
G	Chrome plated stainless steel (17-4)

Air reservoir	
A	Without piston rod

Rod extension or trunnion mounting	
0000	Without
P ...	Piston rod extension in mm
6000	Trunnion mount +90° vs. air ports
7000	Trunnion mount +0° vs. air ports
H ...	Piston rod extension in mm with trunnion +90°
8 ...	Piston rod extension in mm with trunnion +0°
3 ...	Special rod end

Temperature range	
M	Polyurethane (PUR) -20°C to +80°C std temp
F	Fluoro elastomere (FKM) -10°C to +150°C high temp ²
L	Ultrathane polyurethane (TPU-PUR) -40°C to +80°C low temp ²
Q	(TPU-PUR) with metallic scraper -30°C to +80°C low temp ³

¹ In standard temperature range -20°C to +80°C
² High and low temp option only with aluminum piston
³ Only in combination with chrome or stainless steel plated piston rod material
⁴ For air reservoir

Standard strokes for all P1F cylinders compliant to ISO 4393
 (with the exception of stroke 40 mm)
 Non standard strokes up to 2000 mm.

P1F Cylinders in Stock, Cushions and Magnetic Piston Included

Stroke (mm)	32 mm Bore	40 mm Bore	50 mm Bore	63 mm Bore	80 mm Bore
25	P1F-S032MC-0025-0000	P1F-S040MC-0025-0000	P1F-S050MC-0025-0000	P1F-S063MC-0025-0000	P1F-S080MC-0025-0000
40	P1F-S032MC-0040-0000	P1F-S040MC-0040-0000	P1F-S050MC-0040-0000	P1F-S063MC-0040-0000	P1F-S080MC-0040-0000
50	P1F-S032MC-0050-0000	P1F-S040MC-0050-0000	P1F-S050MC-0050-0000	P1F-S063MC-0050-0000	P1F-S080MC-0050-0000
80	P1F-S032MC-0080-0000	P1F-S040MC-0080-0000	P1F-S050MC-0080-0000	P1F-S063MC-0080-0000	P1F-S080MC-0080-0000
100	P1F-S032MC-0100-0000	P1F-S040MC-0100-0000	P1F-S050MC-0100-0000	P1F-S063MC-0100-0000	P1F-S080MC-0100-0000
125	P1F-S032MC-0125-0000	P1F-S040MC-0125-0000	P1F-S050MC-0125-0000	P1F-S063MC-0125-0000	P1F-S080MC-0125-0000
160	P1F-S032MC-0160-0000	P1F-S040MC-0160-0000	P1F-S050MC-0160-0000	P1F-S063MC-0160-0000	P1F-S080MC-0160-0000
200	P1F-S032MC-0200-0000	P1F-S040MC-0200-0000	P1F-S050MC-0200-0000	P1F-S063MC-0200-0000	P1F-S080MC-0200-0000
250	P1F-S032MC-0250-0000	P1F-S040MC-0250-0000	P1F-S050MC-0250-0000	P1F-S063MC-0250-0000	P1F-S080MC-0250-0000
320	P1F-S032MC-0320-0000	P1F-S040MC-0320-0000	P1F-S050MC-0320-0000	P1F-S063MC-0320-0000	P1F-S080MC-0320-0000
400	P1F-S032MC-0400-0000	P1F-S040MC-0400-0000	P1F-S050MC-0400-0000	P1F-S063MC-0400-0000	P1F-S080MC-0400-0000



For inventory, lead times, and kit lookup, visit www.pdnplu.com

Cylinder forces

Bore/piston rod [mm]	Stroke	Surface area [cm ²]	Max theoretical force in N in relation to applied pressure in bar									
			1	2	3	4	5	6	7	8	9	10
32/12	+	8.0	80	161	241	322	402	483	563	643	724	804
	-	6.9	69	138	207	276	346	415	484	553	622	691
40/16	+	12.6	126	251	377	503	628	754	880	1005	1131	1257
	-	10.6	106	211	317	422	528	633	739	844	950	1056
50/20	+	19.6	196	393	589	785	982	1178	1374	1571	1767	1964
	-	16.5	165	330	495	660	825	990	1155	1319	1484	1649
63/20	+	31.2	312	623	935	1247	1559	1870	2182	2494	2806	3117
	-	28.0	280	561	841	1121	1402	1682	1962	2242	2523	2803
80/25	+	50.3	503	1005	1508	2011	2513	3016	3519	4021	4524	5027
	-	45.4	454	907	1361	1814	2268	2721	3175	3629	4082	4536
100/25	+	78.5	785	1571	2356	3142	3927	4712	5498	6283	7069	7854
	-	73.6	736	1473	2209	2945	3682	4418	5154	5891	6627	7363
125/32	+	122.7	1227	2454	3682	4909	6136	7363	8590	9818	11045	12272
	-	114.7	1147	2294	3440	4587	5734	6881	8027	9174	10321	11468

+ = outward stroke
- = return stroke

Cylinder air consumption

Bore/piston rod [mm]	Stroke	Surface area [cm ²]	Air consumption in l/mm in relation to applied pressure in bar									
			1	2	3	4	5	6	7	8	9	10
32/12 (G1/8)	+	8.0	0.016	0.024	0.032	0.040	0.048	0.056	0.064	0.072	0.079	0.087
	-	6.9	0.014	0.021	0.027	0.034	0.041	0.048	0.055	0.061	0.068	0.075
40/16 (G1/4)	+	12.6	0.025	0.037	0.050	0.062	0.075	0.087	0.099	0.112	0.124	0.137
	-	10.6	0.021	0.031	0.042	0.052	0.063	0.073	0.083	0.094	0.104	0.115
50/20 (G1/4)	+	19.6	0.039	0.058	0.078	0.097	0.117	0.136	0.155	0.175	0.194	0.213
	-	16.5	0.033	0.049	0.065	0.082	0.098	0.114	0.130	0.147	0.163	0.179
63/20 (G3/8)	+	31.2	0.062	0.093	0.123	0.154	0.185	0.216	0.247	0.277	0.308	0.339
	-	28.0	0.056	0.083	0.111	0.139	0.166	0.194	0.222	0.249	0.277	0.305
80/25 (G3/8)	+	50.3	0.100	0.150	0.199	0.249	0.298	0.348	0.398	0.447	0.497	0.546
	-	45.4	0.090	0.135	0.180	0.224	0.269	0.314	0.359	0.404	0.448	0.493
100/25 (G1/2)	+	78.5	0.156	0.234	0.311	0.389	0.466	0.544	0.621	0.699	0.776	0.854
	-	73.6	0.146	0.219	0.292	0.364	0.437	0.510	0.582	0.655	0.728	0.800
125/32 (G1/2)	+	122.7	0.244	0.365	0.486	0.607	0.728	0.850	0.971	1.092	1.213	1.334
	-	114.7	0.228	0.341	0.454	0.567	0.681	0.794	0.907	1.020	1.134	1.247

+ extending, - retracting

free air consumption for 1 cycle, 10 mm inward and 10 mm outward

Weight

Bore size mm	P1F-S/A/L/H		P1F-T		Moving parts		Adder for rod lock	
	Base 0 mm kg	per 100 mm kg	Base 0 mm kg	per 100 mm kg	Base 0 mm kg	per 100 mm kg	P1F-H kg	P1F-L kg
32	0.54	0.23	0.49	0.27	0.10	0.09	0.6	0.41
40	0.74	0.32	0.73	0.31	0.19	0.16	0.8	0.44
50	1.22	0.47	1.19	0.52	0.34	0.25	1.0	0.61
63	1.69	0.49	1.68	0.54	0.40	0.24	1.2	1.25
80	2.50	0.73	2.48	0.84	0.73	0.39	1.4	2.45
100	3.65	0.80	3.66	0.88	1.02	0.38	1.6	3.72
125	6.41	1.37	6.30	1.32	2.01	0.63	1.8	6.07



For inventory, lead times, and kit lookup, visit www.pdnplu.com

Product type	Standard cylinder according to ISO 15552
Bore size	32 - 125 mm
Stroke length	5 - 2000 mm
Versions	Double acting
Cushioning	Adjustable air cushioning
Position sensing	Proximity sensor
Installation	ISO cylinder and piston rod mountings



Operating and environmental data

Operating medium	For best possible service life and trouble-free operation dry filtered compressed air to ISO 8573-1:2010 quality 3.4.3 should be used. This specifies a dew point of + 3°C for indoor operation (a lower dew point should be selected for minus temperature operation and we recommend the use of an inline dryer) and is in line with the air quality from most standard compressors with a standard filter.		
Operating pressure	1 to 10 bar		
Ambient temperature	Standard temperature (option M): -20°C to +80°C	Metal scraper (option Q): -30°C to +80°C	
	High temperature (option F): -10°C to +150°C	FKM wiper rod seal (option V): -10°C to +80°C	
	Low temperature (option L): -40°C to + 80°C	POLON wiper rod seal (option D): -20°C to +80°C	
Pre-lubricated	Further lubrication is normally not necessary. If additional lubrication is introduced it must be continued. Hydraulic oil type HLP (DIN 51524. ISO 11158). Viscosity by 40°C: 32 mm2/s (cst). Example: Shell Tellus 32 or equal.		
Corrosion resistance	Material and surface treatment selected for typical industrial applications with resistance to corrosion and chemicals.		

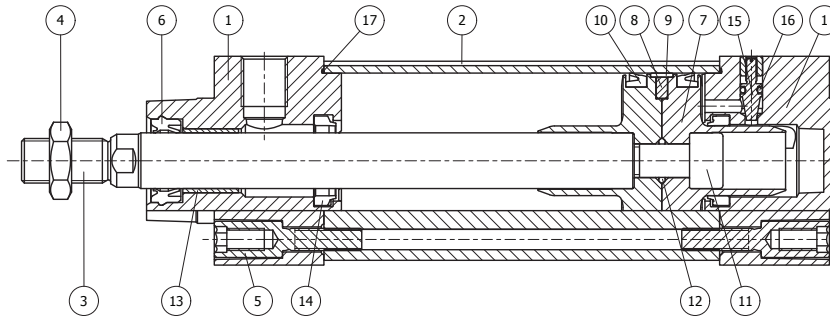

Material specification

Pos	Part	Specification
1	End covers	Aluminum / Optional black anodized (options V & D only)
2	Cylinder barrel	Anodized aluminum (profile or round tube)
3	Piston rod	Standard: Chrome plated carbon steel Optional: Chrome plated stainless steel (17-4)
4	Piston rod nut	Zinc plated steel / Stainless steel (option V & D only)
5	End cover screws	Zinc plated steel / Stainless steel (option V & D only)
6	Piston rod seal	Standard: Polyurethane (PUR) Optional: Fluoro elastomer (FKM) / Ultrathanpolyurethane (TPU-PUR) / Metallic scraper (Brass) nitrile (NBR) / Polon / UHMW-PE
7	Piston	Standard: Poloxymethylene (POM) Optional: Aluminum
8	Magnet	Plastic coated magnetic material
9	Piston bearing	Standard: Poloxymethylene (POM) Optional: Polytetrafluoroethylene (PTFE)
10	Piston seals	Standard: Polyurethane (PUR) Optional: Fluoro elastomer (FKM) / Ultrathanpolyurethane (TPU-PUR)
11	Piston bolt	Zinc plated steel
12	O-ring piston bolt	Standard: Nitrile rubber (NBR) Optional: Fluoro elastomer (FKM)
13	Piston rod bearing	Multilayer steel / PTFE / Optional high polymer (option V & D only)
14	Cushioning seals	Standard: Polyurethane (PUR) Optional: Fluoro elastomer (FKM) / Ultrathanpolyurethane (TPU-PUR)
15	Cushioning screw	Stainless steel DIN X8 CrNiS 18-9
16	O-ring cushioning screw	Standard: Nitrile rubber (NBR) Optional: Fluoro elastomer (FKM)
17	O-ring end cover	Standard: Nitrile rubber (NBR) Optional: Fluoro elastomer (FKM)
	Tie-Rods	Austenitic stainless steel, DIN X8 CrNiS 18-9
	Tie-Rods nut	Zinc plated steel



For inventory, lead times, and kit lookup, visit www.pdnplu.com

Guide for selecting suitable tubing

The selection of the correct size of tubing is often based on experience, with no great thought to optimizing energy efficiency and cylinder velocity. This is usually acceptable, but making a rough calculation can result in worthwhile economic gains.

The following is the basic principle:

1. The primary line to the working valve could be over sized (this does not cause any extra air consumption and consequently does not create any extra costs in operation).
2. The tubes between the valve and the cylinder should, however, be optimized according to the principle that an insufficient bore throttles the flow and thus limits the cylinder speed, while an oversized pipe creates a dead volume which increases the air consumption and filling time.

The following prerequisites apply

The cylinder load should be about 50 % of the theoretical force (= normal load). A lower load gives a higher velocity and vice versa. The tube size is selected as a function of the cylinder bore, the desired cylinder velocity and the tube length between the valve and the cylinder. If you want to use the capacity of the valve to its maximum, and obtain maximum speed, the tubing should be chosen so that they at least correspond with the equivalent restriction diameter (see description below), so that the tubing does not restrict the total flow. This means that a short tubing must have at least the equivalent restriction diameter. If the tubing is longer, choose it from the table below. Straight fittings should be chosen highest flow rates. Rates as elbow and banjo fittings cause restriction.

The chart below is intended to help when selecting the correct size of tube to use between the valve and the cylinder.

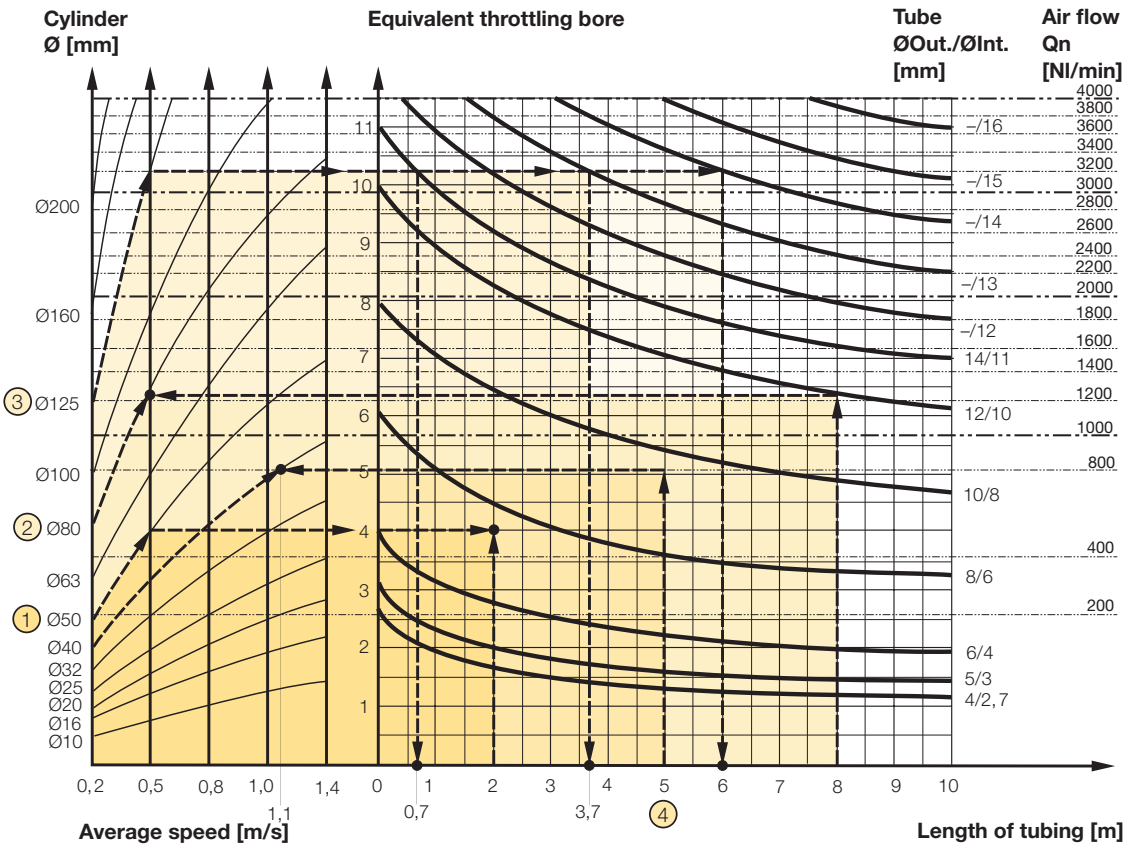

The equivalent throttling bore is a long throttle (for example a tube) or a series of throttles (for example, through a valve) converted to a short throttle which gives a corresponding flow rate. This should not be confused with the orifice which is sometimes specified for valves. The value for the orifice does not normally take account of the fact that the valve contains a number of throttles.

Qn is a measure of the valve flow capacity, with flow measured in liter per minute (l/min) at 6 bar(e) supply pressure and 1 bar pressure drop across the valve.

**Example ① :
Which tube diameter should be used?**

A 50 mm bore cylinder is to be operated at 0.5 m/s. The tube length between the valve and cylinder is 2 m. In the diagram we follow the line from 50 mm bore to 0.5 m/s and get an “equivalent throttling bore” of approximately 4 mm. We continue out to the right in the chart and intersect the line for a 2 m tube between the curves for 4 mm (6/4 tube) and 6 mm (8/6 tube). This means that a 6/4 tube throttles the velocity somewhat, while an 8/6 tube is a little too large. We select the 8/6 tube to obtain full cylinder velocity.

**Example ② :
What cylinder velocity will be obtained?**

A 80 mm bore cylinder will be used, connected by 8 m 12/10 tube to a valve with Qn 1200 NI/min. What cylinder velocity will we get? We refer to the diagram and follow the line from 8 mm tube length up to the curve for 12/10 tube. From there, we go horizontally to the curve for the Ø80 cylinder. We find that the velocity will be about 0.5 m/s.

**Example ③ :
What is the minimum inner diameter and maximum length of tube?**

For an application a 125 mm bore cylinder will be used. Maximum velocity of piston rod is 0.5 m/s. The cylinder will be controlled by a valve with Qn 3200 NI/min. What diameter of tube can be used and what is maximum length of tube.

We refer to the diagram. We start at the left side of the diagram cylinder Ø125. We follow the line until the intersection with the velocity line of 0.5 m/s. From here we draw a horizontal

line in the diagram. This line shows us we need an equivalent throttling bore of approximately 10 mm.

Following this line horizontally we cross a few intersections. These intersections shows us the minimum inner diameter (right side diagram) in combination with the maximum length of tube (bottom side diagram).

For example:

Intersection one: When a tube (14/11) will be used, the maximum length of tube is 0.7 meter.

Intersection two: When a tube (—/13) will be used, the maximum length of tube is 3.7 meter.

Intersection three: When a tube (—/14) will be used, the maximum length of tube is 6 meter.

Example ④ : Determining tube size and cylinder velocity with a particular cylinder and valve?

For an application using a 40 mm bore cylinder with a valve with Qn=800 NI/min. The distance between the cylinder and valve has been set to 5 m.

Tube dimension: What tube bore should be selected to obtain the maximum cylinder velocity? Start at pipe length 5 m, follow the line up to the intersection with 800 NI/min. Select the next largest tube diameter, in this case Ø10/8 mm.

Cylinder velocity: What maximum cylinder velocity will be obtained? Follow the line for 800 NI/min to the left until it intersects with the line for the Ø40 mm cylinder. In this example, the speed is just above 1.1 m/s.

Cushioning Diagram

Work out your expected moving mass and read off the maximum permissible speed at start of cushioning.

Alternatively, take your desired speed and expected mass and find the cylinder size required.

Please note that piston speed at start of cushioning is typically approx. 50 % higher than the average speed, and that it is this higher speed which determines the choice of cylinder.

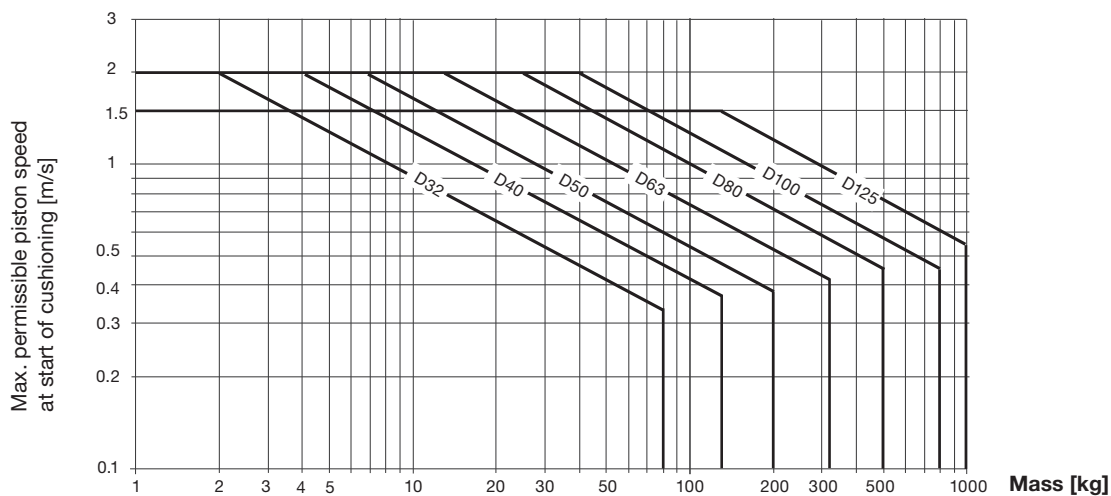

Horizontal application, pressure p = 6 bar, mass guided externally

Cylinder with Rod Lock**Function on pressure loss**

The piston rod lock can be used in all material handling systems where controlled fastening or positioning is required. Additional measures are required for use in safety-related applications (refer to EC Machinery Directive).

The piston rod cylinder with brakes is suitable for use in safety-related sections of control systems. The piston rod lock is also suitable for use as a pressure-loss brake for cylinders with suspended loads, for example. Piston rod can be held in position for long periods even with alternating loads, fluctuating operating pressure or leaks in the system. The signal air to the lock unit can be connected directly to the air system or to the supply air for the valve controlling the cylinder in question. For controlled on/off operation of the lock unit, a separate valve, with large exhaust flow capacity, is used.

Clean and compact design

The front end piece and lock unit form an integrated block, keeping the length of the structure short. The design is easy to clean, sealed and waterproof. The exhaust air from the lock unit can be removed by replacing the filter unit with a connector and hose. This is an advantage in terms of cleaning or when environmental factors are important.

Material specification, piston rod locking

	Dynamic Rod Lock Unit
Housing	Anodized aluminum
Carriage	-
Lock collars	Hardened steel
Springs	Stainless steel
Bore sizes 32-40 mm	UHMWPE plastic
Bore sizes 50-125 mm	Polyurethane PUR
O Rings	Nitrile rubber NBR
Scraper ring	Polyurethane PUR
Air filter	Brass / Sintered bronze

Note!

If a rod guidance module is to be fitted to the brake and the cylinder, as the piston rod extension (WH dimension) is not in accordance with the ISO standard, the piston rod must be extended to provide the same WH dimension as for the cylinder itself.

Cylinder piston rod material must be made in steel or stainless steel chromium plated.

Technical data

Working pressure:	Max 10 bar
Working media:	Dry filtered compressed air
Working temperature:	-20 to +80°C
Release pressure 1):	Min 4 bar +/- 10%

1) Signal pressure to inlet port of lock unit

Static lock forces

Cylinder bore [mm]	Lock force [N] dyn. rod lock
Ø32	550
Ø40	860
Ø50	1345
Ø63	2140
Ø80	3450
Ø100	5390
Ø125	8425

Locking and braking

The static locking force corresponds to 7 bar pressure. Under certain circumstances, the lock can also be used as a brake for positioning or similar applications. The maximum values set out in the graph must not be exceeded.

Use as a brake

The table shows the maximum values for speed and braking mass if the cylinder is used as a brake. The cylinder should not be exposed to additional compressive forces as this significantly reduces the external mass that can be braked. The cylinder does not act as a motor during braking. Heat is generated if the brake is used frequently, and this must be taken into account too.

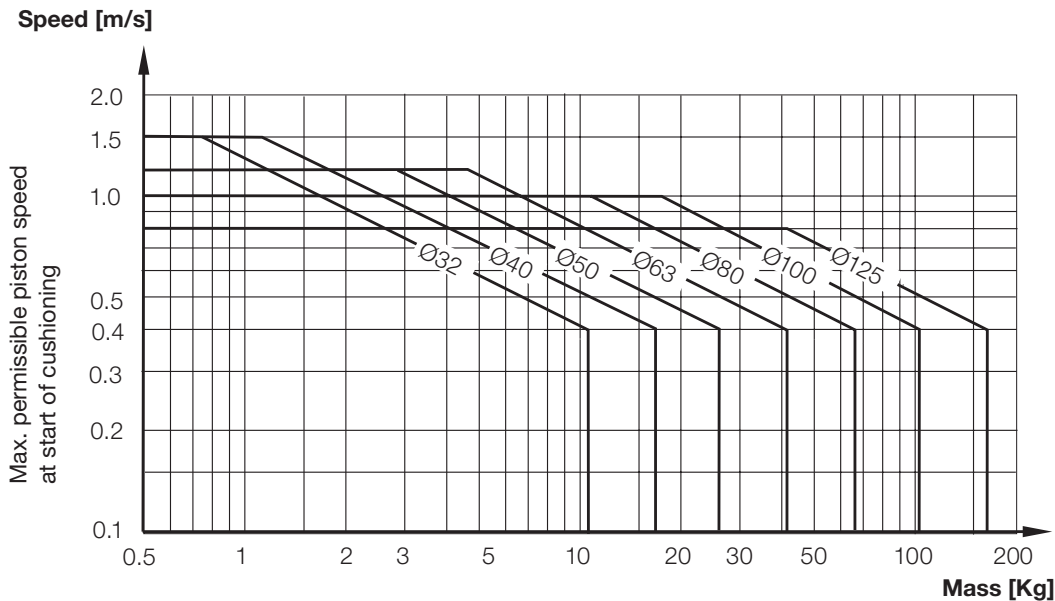

Cushioning Characteristics

Air cushion is used to absorb kinetic energy due to load and speed at both end of stroke. This typically consists of a threaded needle screw that adjusts into an orifice in the cylinder end plate. By adjusting the screw further into the orifice you lessen the amount of air that can escape in a given time. Slowing the exhaust of air creates back pressure which slows the piston as it enters into the end cushioning seal.

The graph is valid for an horizontal movement and the pressure of 6 bar.

The mass is the sum of internal and external friction, plus any gravitational forces. Work out your expected moving mass and read off the maximum permissible speed at start of cushioning. Alternatively, take your desired speed and expected mass and find the cylinder bore size required.

Please note that piston speed at start of cushioning is typically approx. 50 % higher than the average speed and that it is this higher speed which determines the choice of cylinder.

Smooth profile design

P1F-S / P1F-A

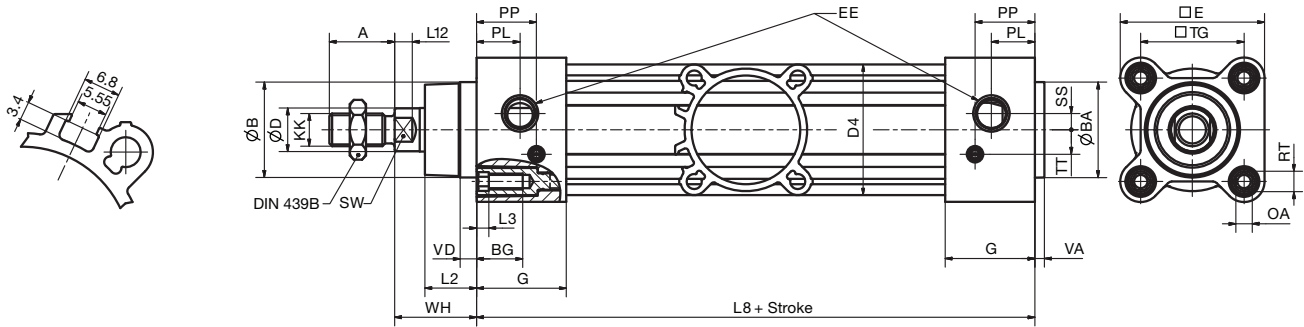

P1F-K

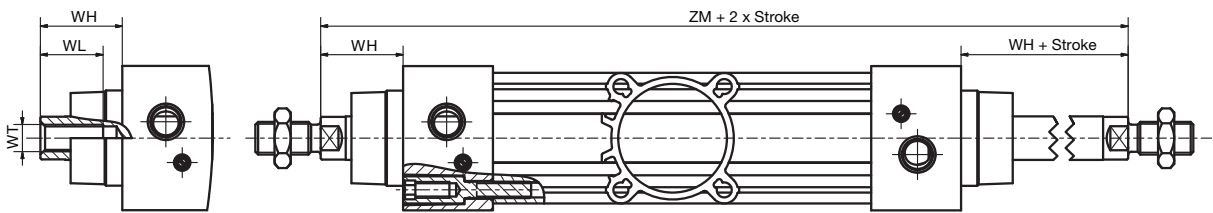

Tie-Rods with round profile design

P1F-T

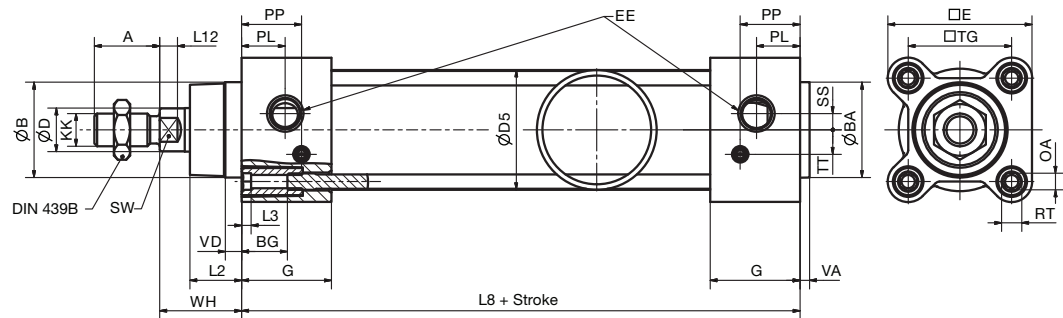

P1F-N

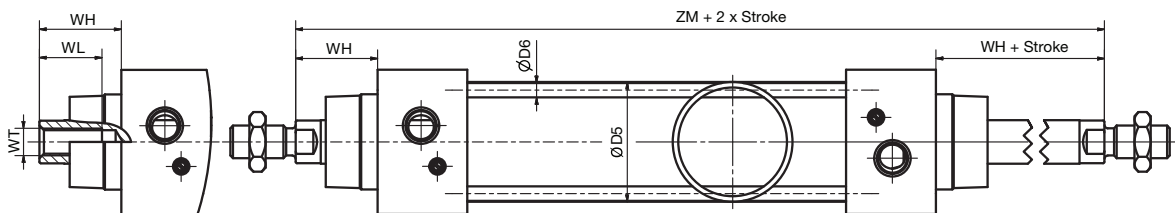

P1F-S, P1F-A, P1F-K, P1F-T, P1F-N [mm]

Bore size	A	ØB d11	ØBA d11	BG	ØD	D4	ØD5	ØD6	E	EE	G	KK	L2	L3	L8
32	22	30	30	17	12	42.5	35	5.3	47	G1/8	28.4	M10x1.25	16.8	4.5	94
40	24	35	35	17	16	48	43	5.3	53	G1/4	33	M12x1.25	19	4.5	105
50	32	40	40	18	20	59.5	54	7.1	64.5	G1/4	33.4	M16x1.5	27.6	4.5	106
63	32	45	45	18	20	69.5	67	7.1	75	G3/8	39.4	M16x1.5	24.3	4.5	121
80	40	45	45	19.5	25	86	85	8.9	94	G3/8	39.4	M20x1.5	30.1	5.5	128
100	40	55	55	19.5	25	103	105	8.9	111	G1/2	44.3	M20x1.5	34	5.5	138
125	54	60	60	20	32	130	130	10.8	136	G1/2	50.8	M27x2	45	0	160

Bore size	L12	OA	PL	PP	RT	SS	SW	TG	TT	VA	VD	WH	WL	WT	ZM
32	6	6	14	20	M6	5	10	32.5	6.5	3.6	6	26	21	M8x1	146
40	6.5	6	16	22	M6	6	13	38	9	3.5	6	30	23	M10x1.25	165
50	8	8	15.5	21.5	M8	6	17	46.5	9	3.6	6	37	31	M14x1.5	180
63	8	8	18	28	M8	10	17	56.5	11	3.5	6	37	31	M14x1.5	195
80	10	10	20	30	M10	11.5	22	72	14	3.5	6	46	39	M18x1.5	220
100	10	10	18	33	M10	11.5	22	89	14	3.5	6	51	39	M18x1.5	240
125	13	8	20	40	M12	0	27	110	22	5.5	9	65	53	M24x2	290

Tolerances [mm]

Bore size	A	L8	TG	ZM	Stroke tolerance		
					s ≤ 350 mm	350 mm < s ≤ 600 mm	s > 600 mm
32	0 / - 0.5	± 0.3	± 0.4	-0.4 /+ 2.2	+ 1.7	+ 1.9	+ 2.3
40	0 / - 0.5	± 0.3	± 0.4	-0.4 /+ 2.2	+ 1.7	+ 1.9	+ 2.3
50	0 / - 0.5	± 0.4	± 0.4	-0.4 /+ 2.2	+ 1.8	+ 2	+ 2.4
63	0 / - 0.5	- 0.5 / + 0.3	± 0.4	-0.4 /+ 2.2	+ 1.9	+ 2.1	+ 2.5
80	0 / - 0.5	± 0.4	± 0.4	-0.4 /+ 2.2	+ 1.9	+ 2.1	+ 2.5
100	0 / - 0.5	± 0.5	± 0.4	-0 /+ 2.5	+ 2.0	+ 2.2	+ 2.6
125	0 / - 1.0	± 0.5	± 0.4	-0 /+ 2.6	+ 2.1	+ 2.3	+ 2.7

Dimensional Data

P1F-L, P1F-P [mm]

Bore size	A	ØB d11	ØBA d11	BG	ØD	D4	E	EE	G	KK	L3	L8	L12	PL	PP	RT
32	22	30	30	17	12	42.5	47	G1/8	28.4	M10x1.25	4.5	94	6	14	20	M6
40	24	35	35	17	16	48	53	G1/4	33	M12x1.25	4.5	105	6.5	16	22	M6
50	32	40	40	18	20	59.5	64.5	G1/4	33.4	M16x1.5	4.5	106	8	15.5	21.5	M8
63	32	45	45	18	20	69.5	75	G3/8	39.4	M16x1.5	4.5	121	8	18	28	M8
80	40	45	45	19.5	25	86	94	G3/8	39.4	M20x1.5	5.5	128	10	20	30	M10
100	40	55	55	19.5	25	103	111	G1/2	44.3	M20x1.5	5.5	138	10	18	33	M10
125	54	60	60	20	32	130	136	G1/2	50.8	M27x2	0	160	13	20	40	M12

Bore size	SS	SW	TG	TT	VA	LE	LG	LK	LL8	LPL	LPP	LSS	LTT	LVD	LWH	LX
32	5	10	32.5	6.5	3.6	50	71	18.5	137	53	63	3	4.5	4	15	6
40	6	13	38	9	3.5	57.4	76.5	20	149	56	67.5	3	3	4	16	6
50	6	17	46.5	9	3.6	70	80	21	153	65	71	8	5.5	4	17	7
63	10	17	56.5	11	3.5	82.4	96	30	178	76.5	87	8.5	3	4	17	7
80	11.5	22	72	14	3.5	100	110	35	199	89	101	9	6	4	20	7
100	11.5	22	89	14	3.5	116	132	54	226	112	122	12	6	4	20	7
125	0	27	110	22	5.5	139	144.5	65.5	254	124.5	134.5	14	6	6	27	7

Tolerances [mm]

Bore size A	L8	TG	Stroke tolerance			
			s ≤ 350 mm	350 mm < s ≤ 600 mm	s > 600 mm	
32	0/-0.5	± 0.3	±0.4	+ 1.7	+ 1.9	+ 2.3
40	0/-0.5	± 0.3	±0.4	+ 1.7	+ 1.9	+ 2.3
50	0/-0.5	- 0.3 / + 0.5	±0.4	+ 1.8	+ 2	+ 2.4
63	0/-0.5	- 0.6 / + 0.2	±0.4	+ 1.9	+ 2.1	+ 2.5
80	0/-0.5	± 0.4	±0.4	+ 1.9	+ 2.1	+ 2.5
100	0/-0.5	± 0.5	±0.4	+ 2.0	+ 2.2	+ 2.6
125	0/-1.0	± 0.5	±0.4	+ 2.1	+ 2.3	+ 2.7

P1F-P

Bore size Ø	Air volume base 0 mm [cm³]	Air volume per stroke of [cm³/100 mm]
32	40	80
40	68	126
50	91	196
63	137	312
80	289	503
100	417	785
125	809	1227



For inventory, lead times, and kit lookup, visit www.pdnplu.com

Mountings

	Flange MF1 / MF2 ①	Foot brackets MS1 ②	Pivot bracket with rigid bearing AB7 ③	Swivel eye bracket MP6 ④	Clevis bracket MP2 ⑤
Bore size mm					
32	P1C-4KMB	P1C-4KMF	P1C-4KMDB	P1C-4KMSB	P1C-4KMTB
40	P1C-4LMB	P1C-4LMF	P1C-4LMDB	P1C-4LMSB	P1C-4LMTB
50	P1C-4MMB	P1C-4MMF	P1C-4MMDB	P1C-4MMSB	P1C-4MMTB
63	P1C-4NMB	P1C-4NMF	P1C-4NMDB	P1C-4NMSB	P1C-4NMTB
80	P1C-4PMB	P1C-4PMF	P1C-4PMDB	P1C-4PMSB	P1C-4PMTB
100	P1C-4QMB	P1C-4QMF	P1C-4QMDB	P1C-4QMSB	P1C-4QMTB
125	P1C-4RMB	P1C-4RMF	P1C-4RMDB	P1C-4RMSB	P1C-4RMTB
	Clevis bracket MP4 ⑥	Clevis bracket AB6 ⑦	Pivot bracket with swivel bearing CS7 ⑧	3 and 4 position flange JP1 ⑨	Pivot brackets AT4 ⑩
Bore size mm					
32	P1C-4KMEB	P1C-4KMCB	P1C-4KMAF	P1E-6KB0	9301054261
40	P1C-4LEB	P1C-4LMCB	P1C-4LMAF	P1E-6LB0	9301054262
50	P1C-4MMEB	P1C-4MMCB	P1C-4MMAF	P1E-6MB0	9301054262
63	P1C-4NEB	P1C-4NMCB	P1C-4NMAF	P1E-6NB0	9301054264
80	P1C-4PEB	P1C-4PMC	P1C-4PMAF	P1E-6PB0	9301054264
100	P1C-4QMEB	P1C-4QMCB	P1C-4QMAF	P1E-6QB0	9301054266
125	P1C-4REB	P1C-4RMCB	P1C-4RMAF	—	9301054266
	Flange trunnion MT5/MT6 ⑪	Intermediate trunnion MT4 ⑫	Swivel rod eye AP6 ⑬	Clevis AP2 ⑭	Flexo coupling PM5 ⑮
Bore size mm				 Galvanized steel Stainless steel	
32	P1D-4KMYF	refer to page 22	P1C-4KRS	P1C-4KRC P1S-4JRD	P1C-4KRF
40	P1D-4LMYF	refer to page 22	P1C-4LRS	P1C-4LRC P1S-4LRD	P1C-4LRF
50	P1D-4MMYF	refer to page 22	P1C-4MRS	P1C-4MRC P1S-4MRD	P1C-4MRF
63	P1D-4NMYF	refer to page 22	P1C-4MRS	P1C-4MRC P1S-4MRD	P1C-4MRF
80	P1D-4PMYF	refer to page 22	P1C-4PRS	P1C-4PRC P1S-4PRD	P1C-4PRF
100	P1D-4QMYF	refer to page 22	P1C-4PRS	P1C-4PRC P1S-4PRD	P1C-4PRF
125	—	refer to page 22	P1C-4RRS	P1C-4RRC P1S-4RRD	P1C-4RRF

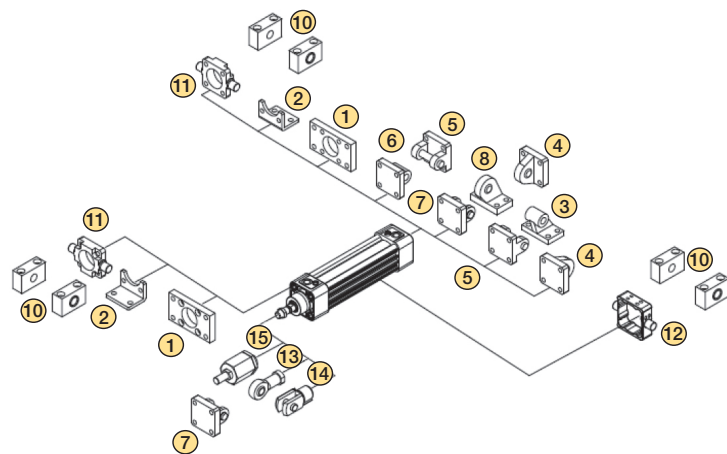

Flange - MF1 / MF2



Intended for fixed mounting of cylinder. Flange can be fitted to front or rear end cover of cylinder.

Materials:

Flange: Surface-treated steel
Mounting screws acc. to DIN 6912:
Zinc-plated steel 8.8
Supplied complete with mounting screws for attachment to the cylinder.

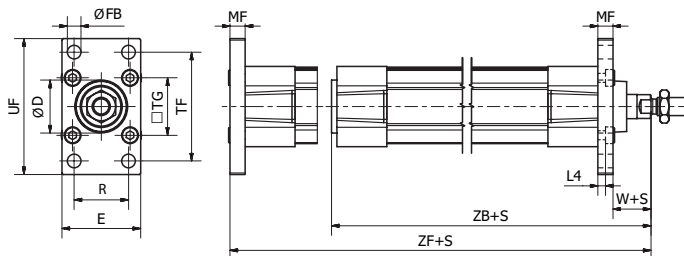

According to ISO 15552

Bore size mm	D (H11) mm	E mm	ØFB (H13) mm	L4 mm	MF mm	R mm	TF mm	TG mm	UF mm	W* mm	ZB* mm	ZF* mm	Weight kg	Part number
32	30	45	7	5.0	10	32	64	32.5	80	16	123.5	130	0.21	P1C-4KMB
40	35	52	9	5.0	10	36	72	38.0	90	20	138.5	145	0.27	P1C-4LMB
50	40	65	9	6.5	12	45	90	46.5	110	25	146.5	155	0.53	P1C-4MMB
63	45	75	9	6.5	12	50	100	56.5	120	25	161.5	170	0.66	P1C-4NMB
80	45	95	12	9.0	16	63	126	72.0	150	30	177.5	190	1.45	P1C-4PMB
100	55	115	14	9.0	16	75	150	89.0	170	35	192.5	205	1.60	P1C-4QMB
125	60	140	16	10.5	20	90	180	110.0	205	45	230.5	245	3.34	P1C-4RMB

*Does not apply to cylinders with piston rod extension or lock units.

Foot Bracket - MS1



Intended for fixed mounting of cylinder. Foot bracket can be fitted to front or rear end cover of the cylinder.

Materials:

Flange: Surface-treated steel
Mounting screws acc. to DIN 6912:
Zinc-plated steel 8.8:

Supplied complete with mounting screws for attachment to the cylinder.

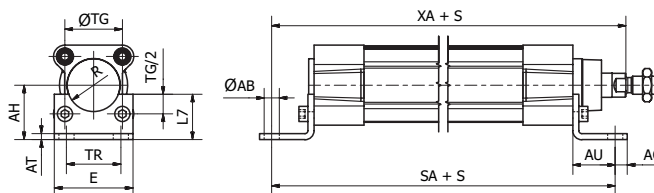

According to ISO 15552

Bore size mm	ØAB (H14) mm	AH (JS15) mm	AO mm	AT mm	AU mm	E mm	L7 mm	R mm	SA* mm	TG mm	TR (JS14) mm	XA* mm	Weight ** kg	Part number
32	7.0	32	11	4	24	45	30	15.0	142	32.5	32	144	0.08	P1C-4KMF
40	10.0	36	8	4	28	52	30	17.5	161	38.0	36	163	0.09	P1C-4LMF
50	10.0	45	15	5	32	65	36	20.0	170	46.5	45	175	0.18	P1C-4MMF
63	10.0	50	13	5	32	75	35	22.5	185	56.5	50	190	0.20	P1C-4NMF
80	12.0	63	14	6	41	95	47	22.5	210	72.0	63	215	0.40	P1C-4PMF
100	14.5	71	16	6	41	115	53	27.5	220	89.0	75	230	0.54	P1C-4QMF
125	16.5	90	25	8	45	140	70	30.0	250	110.0	90	270	1.10	P1C-4RMF

*Does not apply to cylinders with piston rod extension or lock units.

** per bracket

Pivot Bracket with Rigid Bearing - AB7

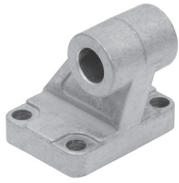

Intended for flexible mounting of cylinder. The pivot bracket can be combined with clevis bracket MP2.

Materials:
Pivot bracket: Aluminum
(Bush: Steel and PTFE)

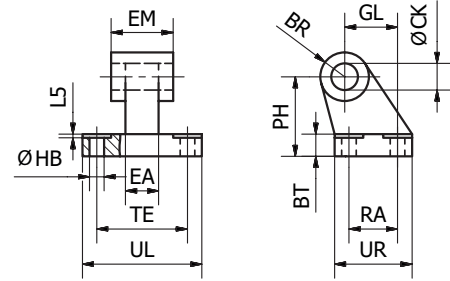

According to ISO 15552

Bore size mm	CK mm	HB mm	L5 mm	TE mm	UL mm	GL mm	RA mm	EA mm	EM mm	UR mm	PH mm	BT mm	BR mm	Weight kg	Part number
32	10	6.6	1.6	38	51	21	18	10	26	31	32	8	10.0	0.05	P1C-4KMDB
40	12	6.6	1.6	41	54	24	22	15	28	35	36	10	11.0	0.09	P1C-4LMDB
50	12	9.0	1.6	50	65	33	30	16	32	45	45	12	13.0	0.16	P1C-4MMDB
63	16	9.0	1.6	52	67	37	35	16	40	50	50	14	15.0	0.20	P1C-4NMDB
80	16	11.0	2.5	66	86	47	40	20	50	60	63	14	15.0	0.32	P1C-4PMDB
100	20	11.0	2.5	76	96	55	50	20	60	70	71	17	19.0	0.53	P1C-4QMDB
125	25	14.0	3.2	94	124	70	60	30	70	90	90	20	22.5	1.01	P1C-4RMDB

Swivel Eye Bracket - MP6

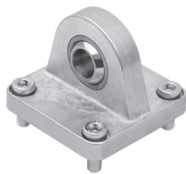

Intended for use together with clevis bracket AB6.

Materials:
Bracket: Aluminum
Swivel bearing acc. to DIN 648K:
Hardened steel

Supplied complete with mounting screws for attachment to cylinder.

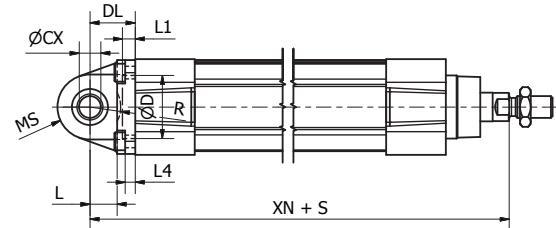
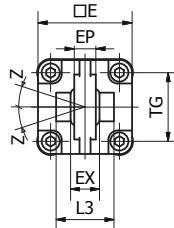

According to ISO 15552

Bore size mm	CX mm	D mm	DL mm	E mm	EP mm	EX mm	L mm	L1 mm	L3 mm	L4 mm	MS mm	R mm	TG mm	XN* mm	Z mm	Weight kg	Part number
32	10	30	22	45	10.5	14	12	7	-	5.5	16	-	32.5	142	4°	0.09	P1C-4KMSB
40	12	35	25	52	12	16	15	7	-	5.5	18	-	38	160	4°	0.13	P1C-4LMSB
50	16	40	27	65	15	21	15	7	51	6.5	21	19	46.5	170	4°	0.24	P1C-4MMSB
63	16	45	32	75	15	21	20	7	-	6.5	23	-	56.5	190	4°	0.29	P1C-4NMSB
80	20	45	36	95	18	25	20	9	74	10	28	24	72	210	4°	0.59	P1C-4PMSB
100	20	55	41	115	18	25	25	9	140	10	30	32	89	230	4°	0.78	P1C-4QMSB
125	30	60	50	140	25	37	30	9	-	10	40	-	110	275	4°	1.38	P1C-4RMSB

*Does not apply to cylinders with piston rod extension or lock units.

Clevis Bracket - MP2



Intended for flexible mounting of cylinder. Can be combined with clevis bracket MP4 and pivot bracket with rigid bearing AB7.

Materials:

- Clevis bracket: Aluminum
- Pin: Surface hardened steel
- Locking pin: Spring steel
- Circlips according to DIN 471: Spring steel
- Mounting screws acc. to DIN 912: Zinc-plated steel 8.8

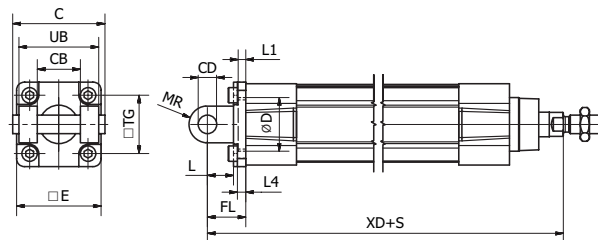

Supplied complete with mounting screws for attachment to the cylinder.

According to ISO 15552

Bore size mm	C mm	E mm	UB mm	CB mm	TG mm	FL mm	L1 mm	L mm	L4 mm	D mm	CD mm	MR mm	XD* mm	Weight kg	Part number
32	53	45	45	26	32.5	22	5	13	5.5	30	10	10	142	0.08	P1C-4KMTB
40	60	52	52	28	38	25	5	16	5.5	35	12	12	160	0.10	P1C-4LMTB
50	68	65	60	32	46.5	27	5	16	6.5	40	12	12	170	0.18	P1C-4MMTB
63	78	75	70	40	56.5	32	5	21	6.5	45	16	16	190	0.24	P1C-4NMTB
80	98	95	90	50	72	36	5	22	10	45	16	16	210	0.49	P1C-4PMTB
100	118	115	110	60	89	41	5	27	10	55	20	20	230	0.73	P1C-4QMTB
125	139	140	130	70	110	50	7	30	10	60	25	25	275	1.37	P1C-4RMTB

*Does not apply to cylinders with piston rod extension or lock units.

Clevis Bracket - MP4



Intended for flexible mounting of cylinder. Clevis bracket MP4 can be combined with clevis bracket MP2.

Materials:

- Clevis bracket: Aluminum
- Bush: Steel and PTFE
- Mounting screws acc. to DIN 912: Zinc-plated steel 8.8

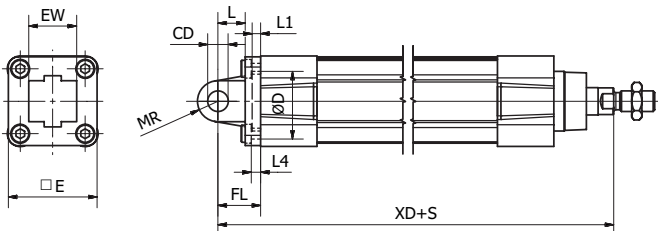

Supplied complete with mounting screws for attachment to the cylinder.

According to ISO 15552

Bore size mm	CD mm	D mm	E mm	EW mm	FL mm	L mm	L1 mm	L4 mm	MR mm	TG mm	XD* mm	Weight kg	Part number
32	10	30	47	26	22	12	6.5	6	10.5	32.5	142	0.08	P1C-4KMEB
40	12	35	52	28	25	16	5	5.5	12	38	160	0.11	P1C-4LMEB
50	12	40	65	32	27	16	5	6.5	12	46.5	170	0.18	P1C-4MMEB
63	16	45	78	40	32	21	5	6.5	16	56.5	190	0.28	P1C-4NMEB
80	16	45	95	50	36	22	5	10	16	72	210	0.52	P1C-4PMEB
100	20	55	115	60	41	27	5	10	20	89	230	0.79	P1C-4QMEB
125	25	60	140	70	50	30	7	10	25	110	275	1.46	P1C-4RMEB

*Does not apply to cylinders with piston rod extension or lock units.



For inventory, lead times, and kit lookup, visit www.pdnplu.com

Clevis Bracket - AB6

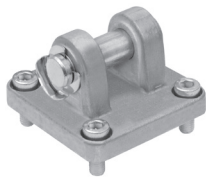

Intended for flexible mounting of cylinder. Clevis bracket AB6 can be combined with pivot brackets MP6 and CS7 or swivel rod eye AP6.

Materials:

Clevis bracket: Aluminum
Pin: Surface hardened steel
Locking pin: Spring steel
Circlips according to DIN 471: Spring steel
Mounting screws acc. to DIN 912: Zinc-plated steel 8.8
Supplied complete with mounting screws for attachment to the cylinder.

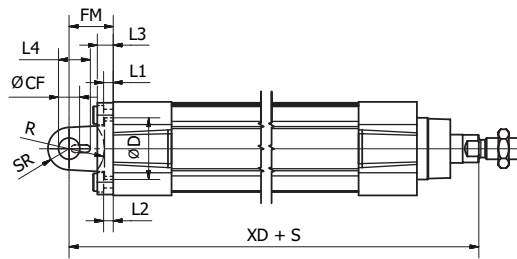
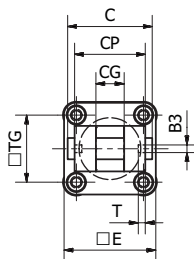

According to ISO 15552

Bore size mm	B3 mm	C mm	CF mm	CG mm	CP mm	D mm	E mm	FM mm	I2 mm	T mm	R mm	L1 mm	L4 mm	L3 mm	SR mm	TG mm	XD* mm	Weight kg	Part number
32	3.3	41	10	14	34	30	45	22	5.5	3	17	5	16.5	9	10	32.5	142	0.04	P1C-4KMCB
40	4.3	48	12	16	40	35	52	25	5.5	4	20	5	18	9	12	38	160	0.07	P1C-4LMCB
50	4.3	54	16	21	45	40	65	27	6.5	4	22	5	22	11	14	46.5	170	0.11	P1C-4MMCB
63	4.3	60	16	21	51	45	75	32	6.5	4	25	5	22	11	18	56.5	190	0.19	P1C-4NMCB
80	4.3	75	20	25	65	45	95	36	10.0	4	30	5	26	14	20	72	210	0.38	P1C-4PMCB
100	6.3	85	20	25	75	55	115	41	10.0	4	32	5	26	14	22	89	230	0.61	P1C-4QMCB
125	6.3	110	30	37	97	60	140	50	10.0	6	42	7	39	20	25	110	275	1.10	P1C-4RMCB

*Does not apply to cylinders with piston rod extension or lock units.

Pivot Bracket with Swivel Bearing - CS7



Intended for use together with clevis bracket AB6.

Materials:

Pivot bracket: Aluminum
Swivel bearing acc. to DIN 648K:
Hardened steel

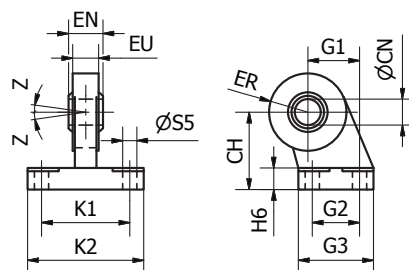

According to ISO 15552

Bore size mm	CN mm	S5 mm	K1 mm	K2 mm	EU mm	G1 mm	G2 mm	EN mm	G3 mm	CH mm	H6 mm	ER mm	Z mm	Weight kg	Part number
32	10	6.6	38	51	10.5	21	18	14	31	32	10	15	4°	0.18	P1C-4KMAF
40	12	6.6	41	54	12.0	24	22	16	35	36	10	18	4°	0.27	P1C-4LMAF
50	16	9.0	50	65	15.0	33	30	21	45	45	12	20	4°	0.46	P1C-4MMAF
63	16	9.0	52	67	15.0	37	35	21	50	50	12	23	4°	0.55	P1C-4NMAF
80	20	11.0	66	86	18.0	47	40	25	60	63	14	27	4°	0.97	P1C-4PMAF
100	20	11.0	76	96	18.0	55	50	25	70	71	15	30	4°	1.33	P1C-4QMAF
125	30	13.5	94	124	25.0	70	60	37	90	90	20	40	4°	3.00	P1C-4RMAF



For inventory, lead times, and kit lookup, visit www.pdnplu.com

3 and 4 Position Flange - JP1



Mounting kit for back to back mounted cylinders, 3 and 4 position cylinders.

Materials:

Mounting: Aluminum
Mounting screws: Zinc-plated steel 8.8

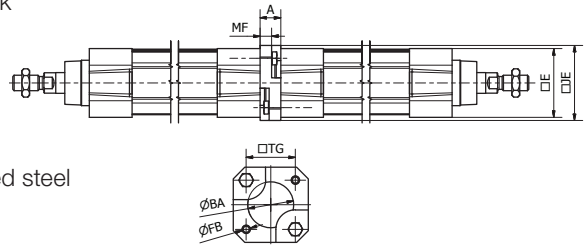

Bore size mm	A mm	ØBA mm	E mm	ØFB mm	JE mm	MF mm	TG mm	Weight kg	Part number
32	16	30	47	6.5	50	9	32.5	0.04	P1E-6KB0
40	16	35.5	53	6.5	58	9	38.0	0.07	P1E-6LB0
50	20	40.5	64.5	8.5	66	6	46.5	0.08	P1E-6MB0
63	20	45.5	75	8.5	80	6	56.5	0.16	P1E-6NB0
80	25	45.5	94	10.5	99	8	72.0	0.30	P1E-6PB0
100	25	55.5	111	10.5	118	8	89.0	0.54	P1E-6QB0

Pivot Brackets for MT Trunnion - AT4

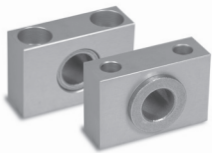

Intended for use together with trunnion MT4.

Materials:

Pivot bracket: Surface-treated aluminum
Bush: Bronze
Supplied in pairs

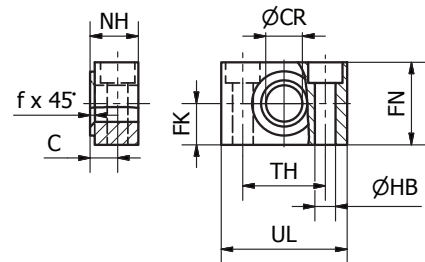

According to ISO 15552

Bore size mm	UL mm	NH mm	TH mm	C mm	CR mm	HB mm	FN mm	FK mm	fx45° mm	Weight kg	Part number
32	46	18	32	10.5	12	6.6	30	15	1.0	0.08	9301054261
40	55	21	36	12.0	16	9	36	18	1.6	0.14	9301054262
50	55	21	36	12.0	16	9	36	18	1.6	0.14	9301054262
63	65	23	42	13.0	20	11	40	20	1.6	0.21	9301054264
80	65	23	42	13.0	20	11	40	20	1.6	0.21	9301054264
100	75	28.5	50	16.0	25	14	50	25	2.0	0.36	9301054266
125	75	28.5	50	16.0	25	14	50	25	2.0	0.36	9301054266

Flange Trunnion - MT5 / MT6



Intended for articulated mounting of cylinder. This trunnion can be flange mounted on the front or rear end cover of the cylinder.

Materials:

Trunnion: Zinc-plated steel
Screws: Zinc-plated steel 8.8
Delivered complete with mounting screws for attachment to the cylinder.

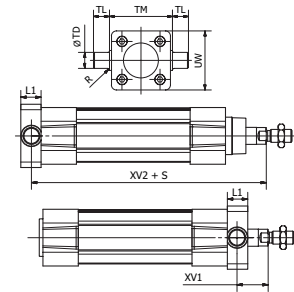

According to ISO 15552

Bore size mm	L1 mm	R mm	TD (e9) mm	TL (h14) mm	TM (h14) mm	UW mm	XV1* mm	XV2* mm	Weight kg	Part number
32	14	1.0	12	12	50	46	19.5	127.0	0.14	P1D-4KMYF
40	19	1.6	16	16	63	59	21.0	144.5	0.39	P1D-4LMYF
50	19	1.6	16	16	75	69	28.0	152.5	0.51	P1D-4MMYF
63	24	1.6	20	20	90	84	25.5	170.0	1.04	P1D-4NMYF
80	24	1.6	20	20	110	102	34.5	186.0	1.57	P1D-4PMYF
100	29	2.0	25	25	132	125	37.0	203.5	3.00	P1D-4QMYF

* Does not apply to cylinders with piston rod extension or lock units.

To fit a flange mounted trunnion at the front end cover of a cylinder with lock unit, the piston rod must be extended. This is in order to provide the same WH dimensions as for the P1F base cylinder.

Center Trunnion - MT4



Available for P1F Profile and Tie-Rods versions the MT4 center trunnion when combined with AT4 pivot brackets is intended for articulated mounting of the cylinder. The trunnion is free so that it can be fixed afterward when the cylinder is at the right place on the machine.

Material: Zinc plated steel

Refer to the model code page 16 for ordering cylinder with trunnion.

Important note: the rear end cylinder cover needs to be removed for adding the trunnion when ordered as a single kit.

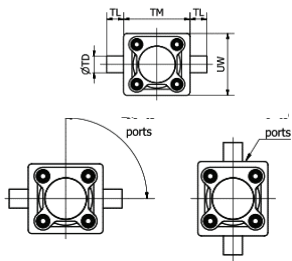
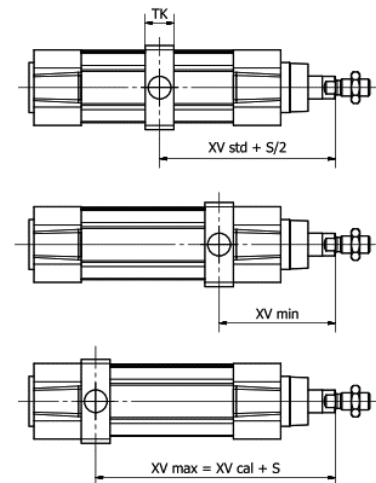

According to ISO 15552					P1F-S/K		P1F-T/N		P1F-L	P1F-H	Part number				
Bore size mm	TL mm	TM mm	ØTD mm	XV* mm	TK mm	UW mm	XV* min mm	XV* cal mm	TK mm	UW mm	XV* min mm	XV* cal mm	Adder to XV*	Smooth Profile	Tie-Rods
32	12	50	12	73	18	52	65	81	15	46	63	83	32	48	P1F-4KMY P1F-4KMYT
40	16	63	16	83	20	60	74	91	20	59	74	91	30	55	P1F-4LMY P1F-4LMYT
50	16	75	16	90	20	71	82	98	20	69	82	98	29	70	P1F-4MMY P1F-4MMYT
63	20	90	20	98	26	84	91	104	25	84	90	105	39	70	P1F-4NMY P1F-4NMYT
80	20	110	20	110	26	105	100	120	25	102	99	121	45	90	P1F-4PMY P1F-4PMYT
100	25	132	25	120	32	129	113	127	30	125	112	128	57	92	P1F-4QMY P1F-4QMYT
125	25	160	25	145	33	154	134	156	33	155	134	156	56	122	P1F-4RMY P1F-4RMYT

*Does not apply to cylinders with piston rod extension or lock units.



For inventory, lead times, and kit lookup, visit www.pdnplu.com

Swivel Rod Eye - AP6



Swivel rod eye for articulated mounting of the cylinder. Swivel rod eye can be combined with clevis bracket AB6.

Materials:

Swivel rod eye: Zinc-plated steel
Swivel bearing according to DIN 648K: hardened steel

Swivel rod eye: Stainless steel
Swivel bearing according to DIN 648K: Hardened steel

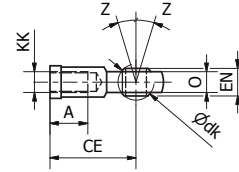
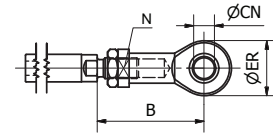

According to ISO 8139

Bore size mm	A mm	B min mm	B max mm	CE mm	CN mm	EN mm	ER mm	KK	LE dk	N mm	O mm	Z	Weight kg	Part number	
														Galvanized steel	Stainless steel
32	15	48.0	55	43	10	14	29	M10x1.25	19.0	17	10.5	13°	0.07	P1C-4KRS	P1S-4JRT
40	18	56.0	62	50	12	16	33	M12x1.25	22.2	19	12.0	13°	0.11	P1C-4LRS	P1S-4LRT
50	24	72.0	80	64	16	21	43	M16x1.5	28.5	22	15.0	15°	0.21	P1C-4MRS	P1S-4MRT
63	24	72.0	80	64	16	21	43	M16x1.5	28.5	22	15.0	15°	0.21	P1C-4MRS	P1S-4MRT
80	30	87.0	97	77	20	25	51	M20x1.5	34.9	30	18.0	15°	0.38	P1C-4PRS	P1S-4PRT
100	30	87.0	97	77	20	25	51	M20x1.5	34.9	30	18.0	15°	0.38	P1C-4PRS	P1S-4PRT
125	45	123.5	137	110	30	37	70	M27x2	50.8	41	25.0	15°	1.15	P1C-4RRS	P1S-4RRT

Clevis - AP2

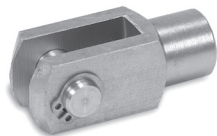

Stainless steel



Galvanized steel

Clevis for articulated mounting of the cylinder.

Materials:

Clevis, clip: Zinc-plated steel
Pin: Hardened steel

Clevis, clip: Stainless steel
Pin: Stainless steel

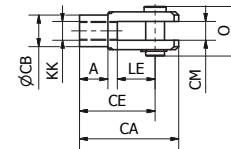
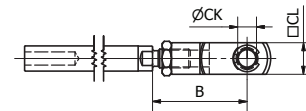

According to ISO 8140

Bore size mm	A mm	B min mm	B max mm	CA mm	CB mm	CE mm	CK mm	CL mm	CM mm	KK	LE mm	O mm	Weight kg	Part number	
														Galvanized steel	Stainless steel
32	15	45	52	52	18	40	10	20	10	M10x1.25	20	25	0.09	P1C-4KRC	P1S-4JRD
40	18	54	60	62	20	48	12	24	12	M12x1.25	24	31	0.15	P1C-4LRC	P1S-4LRD
50	24	72	80	83	26	64	16	32	16	M16x1.5	32	40	0.34	P1C-4MRC	P1S-4MRD
63	24	72	80	83	26	64	16	32	16	M16x1.5	32	40	0.34	P1C-4MRC	P1S-4MRD
80	30	90	100	105	34	80	20	40	20	M20x1.5	40	50	0.67	P1C-4PRC	P1S-4PRD
100	30	90	100	105	34	80	20	40	20	M20x1.5	40	50	0.67	P1C-4PRC	P1S-4PRD
125	40	123.5	137	148	48	110	30	55	30	M27x2.0	54	65	1.80	P1C-4RRC	P1S-4RRD

Flexo Coupling - PM5

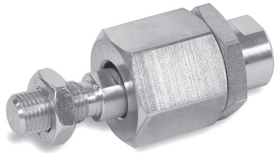

Flexo coupling for articulated mounting of piston rod. Flexo fitting is intended to take up axial angle errors within a range of $\pm 4^\circ$.

Materials:

Flexo coupling, nut: Zinc-plated steel

Supplied complete with galvanized adjustment nut.

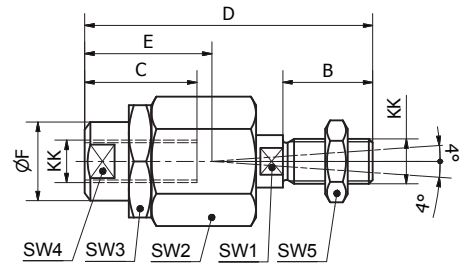

Bore size mm	KK	B mm	C mm	D mm	E mm	ØF mm	SW1 mm	SW2 mm	SW3 mm	SW4 mm	SW5 mm	Weight kg	Part number
32	M10x1.25	20	23	70	31	21	12	30	30	19	17	0.23	P1C-4KRF
40	M12x1.25	24	30	77	31	21	12	30	30	19	19	0.23	P1C-4LRF
50	M16x1.5	32	32	108	45	33.5	19	41	41	30	24	0.65	P1C-4MRF
63	M16x1.5	32	32	108	45	33.5	19	41	41	30	24	0.65	P1C-4MRF
80	M20x1.5	40	42	122	56	33.5	19	41	41	30	30	0.71	P1C-4PRF
100	M20x1.5	40	42	122	56	33.5	19	41	41	30	30	0.71	P1C-4PRF
25	M27x2	54	48	147	51	39	24	55	55	32	41	1.60	P1C-4RRF

Nuts



Intended for fixed mounting of accessories to the piston rod.

Material: Zinc-plated steel

All P1D cylinders are delivered with a zinc-plated steel piston rod nut.

Stainless Steel Nut

Material: Stainless steel A2

Acid-proof nut

Material: Acid-proof steel A4

Cylinders with acid-proof piston rod are supplied with nut of acid-proof steel.

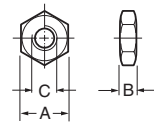

According to DIN 439 B

Bore size mm	A mm	B mm	C	Weight kg	Part numbers		
					Steel	Stainless steel	Acid-proof
32	17	5.0	M10x1.25	0.007	0867340300	9126725404	0261109919
40	19	6.0	M12x1.25	0.010	0867340400	9126725405	0261109920
50	24	8.0	M16x1.5	0.021	0867340600	9126725406	0261109917
63	24	8.0	M16x1.5	0.021			
80	30	10.0	M20x1.5	0.040	0261109911	0261109921	0261109916
100	30	10.0	M20x1.5	0.040			
125	41	13.5	M27x2	0.100	0867340900	0261109922	0261109918
160/200	55	18.0	M36x2	C.F.	L075540036	Consult factory	Consult factory

C.F. = Consult Factory



For inventory, lead times, and kit lookup, visit www.pdnplu.com

Drop-in sensors

The P8S sensors can easily be installed from the side in the sensor groove, at any position along the piston stroke. The sensors are completely recessed and thus mechanically protected. Choose between electronic or reed sensors and several cable lengths and 8 mm and M12 connectors.

**Electronic sensors**

The electronic sensors are “Solid State”, i.e. they have no moving parts at all. They are provided with short-circuit protection and transient protection as standard. The built-in electronics make the sensors suitable for applications with high on and off switching frequency, and where very long service life is required.

Reed sensors

The sensors are based on proven reed switches, which offer reliable function in many applications. Simple installation, a protected position on the cylinder and clear LED indication.

	Electronic	Reed
Cylinder type:	Profile with T-slot	
Cylinder type with adaptor:	Profile with S-slot (dovetail) Tie rods Round cylinders	
Installation:	Drop-in. Fixed by 1.5 mm stainless steel allen key or flathead screwdriver.	
Housing length:	34.7 mm 31.5 mm (ATEX)	
Output Type / Function:	PNP, Normally Open (NO) NPN, Normally Closed (NC)	Normally Open (NO) Normally Closed (NC)
Switching (on/off) switching frequency:	≤1000 Hz	± 400 Hz
Degree of Protection (IP):	IP67	
Power consumption:	≤ 10 mA	-
Input Supply Voltage Range:	10 to 30 V DC 18 to 30 V DC (ATEX)	10 to 30 10 to 120 10 to 230 V AC/DC (2-wire) 10 to 30 V AC/DC (3-wire)
Voltage Drop:	≤ 2,2 V	≤ 3,5 V (2-wire NO) ≤ 0,1 V (3-wire) ≤ 0,1 V (2-wire NC)
Continuous output current:	≤ 100 mA ≤ 70 mA (ATEX)	≤ 100 mA (2-wire NO) ≤ 500 mA (3-wire) ≤ 500 mA (2-wire NC)
Switching capacity:	-	≤ 10 W
Hazardous area category:	3G / 3D (ATEX)	-
Protection Class:	III	II (2-wire) III (3-wire)
Response Sensitivity:	2.65.. 2.95 mT	2.1.. 3.4 mT
Overrun Distance:	3 mm	9 mm
Hysteresis:	≤ 0.5 mT	≤ 0.2 mT
Repeatability:	≤ 0.1 mT	
Reverse Polarity Protection:	Yes	
Short-circuit Protection:	Yes	-
Power-up Pulse Protection:	Yes	-
Ambient Operating Temperature Range:	-25 to +75 °C (PUR cable) -20 to +70°C (PVC cable) -20 to +45°C (ATEX)	
Shock and Vibration resistance:	30 g 11 ms / 10 ... 55 Hz, 1 mm	
EMC:	According to EN 60947-5-2	
Industry Standard:	CE C UL US RoHs Ex	CE C UL US RoHs
UL Certification:	On request	
Housing Material:	Plastic polyamide PA12 (ATEX) PA66	Plastic polyamide PA12 (2-wire 240V) PA66
Cable Specification:	PUR (Polyurethane) PVC (Polyvinyl Chloride)	
Conductor Cross-Section:	0.14 mm ² (3 wire)	0.14 mm ² (3-wire) 0.12 mm ² (2-wire)
Colour of LED:	Yellow	
Connection Style:	M8 snap-in M8R (knurled nuts) M12 (knurled nuts) None (Flying lead)	

Specifications

Electronic sensors

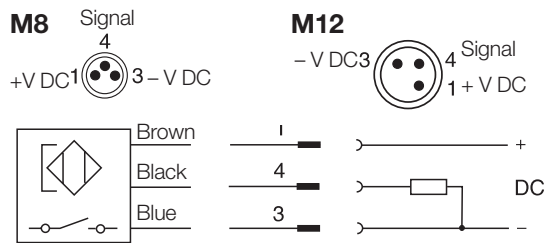

Dimensions [mm]

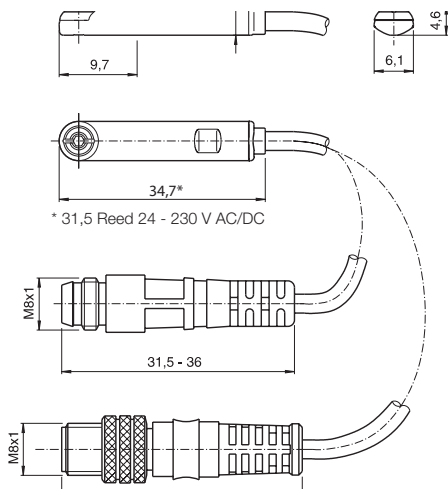

Tie Rod and Profile Pneumatic Cylinders P1F Series

Reed sensors

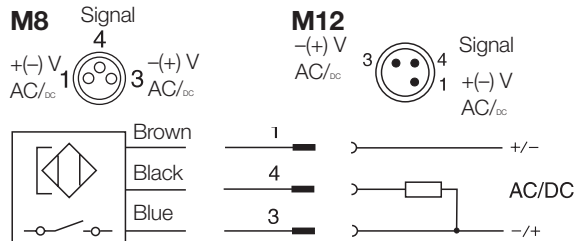

P8S-GCFPX (NC)

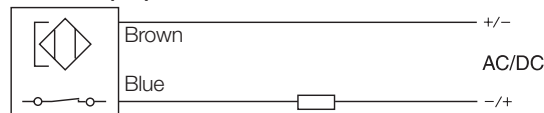

P8S-GRFLX (NO)

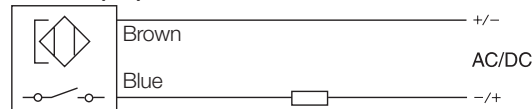

Tie Rod Bracket Assembly

Tie Rod Bracket Assembly is necessary for Global and Mini-Global Sensor installation on all tie rod construction cylinders.

Part number P8S-TMAOX fits 32-200mm bores for Global Sensors

P8S-TMAOX

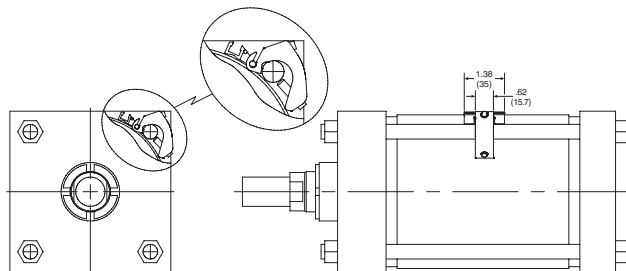

Sensor ordering information

Output/function	Cable/connector	Weight kg	Part number
Electronic sensors, 10-30 V DC			
PNP type, normally open	0.27 m PUR cable and 8 mm snap-in male connector	0.007	P8S-GPSHX
PNP type, normally open	0.27 m PUR cable and M12 screw male connector	0.015	P8S-GPMHX
PNP type, normally open	3 m PVC cable without connector	0.030	P8S-GPFLX
PNP type, normally open	10 m PVC cable without connector	0.110	P8S-GPFTX
Reed sensors, 10-30 V AC/DC			
Normally open	0.27 m PUR cable and 8 mm snap-in male connector	0.007	P8S-GSCHZ
Normally open	0.27 m PUR cable and M12 screw male connector	0.015	P8S-GSMHX
Normally open	3 m PVC cable without connector	0.030	P8S-GSFLX
Normally open	10 m PVC cable without connector	0.110	P8S-GSFTX
Normally closed	5 m PVC cable without connector without LED	0.050	P8S-GCFPX
Reed sensors, 10-120 V AC/DC			
Normally open	3 m PVC cable without connector	0.030	P8S-GRFLX
Reed sensors, 24-230 V AC/DC			
Normally open	3 m PVC cable without connector	0.030	P8SAGRFLX2

Male connectors for connecting cables

Cable connectors for producing your own connecting cables. The connectors can be quickly attached to the cable without special tools. Only the outer sheath of the cable is removed. The connectors are available for M8 screw connectors and meet protection class IP65.



Technical data

Operating voltage:	max. 32V AC/DC
Operating current per contact:	max. 4 A
Connection cross section:	0.25.... 0.5 mm ² (conductor diameter min 0.1)
Protection class:	IP65 And IP67 when plugged and screwed down (EN 60529)
Temperature range:	- 25... +85°C

Connector	Weight kg	Part number
M8 screw connector	0.018	P8CS0803J
M12 screw connector	0.022	P8CS1204J

Connecting cables

Description	Weight g	For Product Series	Part number
Cable flex PVC 3 meter with 8mm snap-in connector / flying leads	70	P8S Sensors with M8	9126344341
Cable flex PVC 10 meter with 8mm snap-in connector / flying leads	210	P8S Sensors with M8	9126344342
Cable PUR 3 meter with 8mm snap-in female connector / flying leads	70	P8S Sensors with M8	9126344345
Cable flex PUR 10 meter with 8mm snap-in connector / flying leads	210	P8S Sensors with M8	9126344346
Cable PVC 2.5 meter with M8 screw connector / flying leads	60	P8S Sensors with knurled M8	4041
Cable PVC 5 meter with M8 screw female connector / flying leads	120	P8S Sensors with knurled M8	KC3104



Specifications

Tie Rod and Profile Pneumatic Cylinders P1F Series

Continuous Position Sensing (CPS)

Analogue signal or IO-Link communication for linear cylinders many applications require more than just end of stroke sensing of an actuator, but traditional methods of continuous sensing are expensive and difficult to implement. Parker's CPS series of the P8S sensor family enables quick, easy, precise, and contactless position sensing of a piston. This can be installed on a standard linear actuator and offers an outstanding price to performance ratio.

Product Features:

- Continuous position sensing
- IO-Link communication with M12 connector
- No modification to the actuator
- Analog version with M8 connector
- 5 sizes with sensing ranges from 32 mm to 256 mm
- IP67 design suitable for any industrial application
- Yellow teach button for easy set-up

Technical specification:

1 ms sampling rate
0.03% full scale resolution
0.06% full scale repeatability
0.3 mm Linearity error

How it installs:

The Parker CPS requires the use of a magnetic piston. The product will fit T-slot cylinders without any additional mounting hardware.

1. Pivot the sensor into the slot
2. Teach the CPS unit the desired measuring range
3. Tighten set screws

Dimensions in mm (inch)

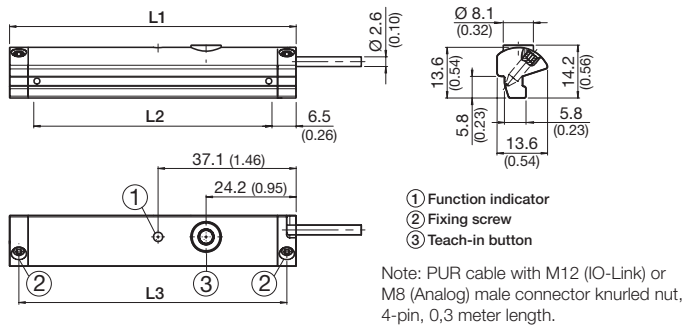

How it connects:

Analog version has a M8 connector and a voltage output of 0-10V as well as a current output of 4-20mA. IO-Link version has a M12 connector and transmits position via 2 bytes of process input data and also allows for parameter control of measuring range and locking of the teach button. It can be controlled by Class A or Class B IO-Link Masters.

How it works:

The CPS product detects the position of an actuator via the magnet on the piston. The sensor settings can easily be adjusted during installation using the yellow teach button or during operation over the IO-Link communication. This upgrades the functionality of the pneumatic actuator by making it more intelligent and versatile in support of the Industry 4.0 initiative.

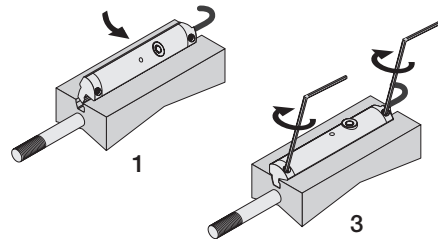

L1	L2 *	L3	Part number	
			Analog	IO-Link
45	32	40	P8SAGACHA	P8SAGHMHA
77	64	72	P8SAGACHB	P8SAGHMHB
141	128	136	P8SAGACHD	P8SAGHMHD
205	192	200	P8SAGACHF	P8SAGMHF
269	256	264	P8SAGACHH	P8SAGMHMH

*L2 equal to the measuring range

Ordering Data - Drop in T-slot, Turn, Screw, it's done

Output	Measuring length	Configuration Option	Order Code	Weight g	For product series
Analog	32 mm	Teach Button	P8SAGACHA	16	With T-slot groove *
	64 mm		P8SAGACHB	26	
	128 mm		P8SAGACHD	46	
	192 mm		P8SAGACHF	66	
	256 mm		P8SAGACHH	86	
IO-Link	32 mm	Teach Button or IO-Link parameter	P8SAGHMHA	20	With T-slot groove *
	64 mm		P8SAGHMHB	30	
	128 mm		P8SAGHMHD	50	
	192 mm		P8SAGMHF	70	
	256 mm		P8SAGMHMH	90	

* Required magnetic field sensitivity: 3mT / -2 mT (Analogue) / 3mT (IO-Link)

Note: PUR cable with M12 (IO-Link) or M8 (Analogue) male connector knurled nut, 4-pin, 0,3 meter length. Please consult for measuring range 96, 160 & 224 mm.



For inventory, lead times, and kit lookup, visit www.pdnplu.com

Seal Kits

Complete seal kits consisting of:

- 2 piston seals
- 2 cushioning seals
- 1 wiper / piston rod seal
- 2 o-rings

Grease Type

Type	Part number
Standard	30 g 9127394541
High temperature	30 g 9127394521
Low temperature	30 g 9127394541

Bore size mm	Standard temperature ¹⁾	High temperature ¹⁾	Low temperature ¹⁾	Metallic scraper ¹⁾²⁾	FKM Wiper seal ¹⁾	With dyn. rod lock ¹⁾
32	P1F-6032RN	P1F-6032RF	P1F-6032RL	P1F-6032RQ	P1F-6032RV	P1F-6032RNL
40	P1F-6040RN	P1F-6040RF	P1F-6040RL	P1F-6040RQ	P1F-6040RV	P1F-6040RNL
50	P1F-6050RN	P1F-6050RF	P1F-6050RL	P1F-6050RQ	P1F-6050RV	P1F-6050RNL
63	P1F-6063RN	P1F-6063RF	P1F-6063RL	P1F-6063RQ	P1F-6063RV	P1F-6063RNL
80	P1F-6080RN	P1F-6080RF	P1F-6080RL	P1F-6080RQ	P1F-6080RV	P1F-6080RNL
100	P1F-6100RN	P1F-6100RF	P1F-6100RL	P1F-6100RQ	P1F-6100RV	P1F-6100RNL
125	P1F-6125RN	P1F-6125RF	P1F-6125RL	P1F-6125RQ	P1F-6125RV	P1F-6125RNL

¹⁾ for through piston rod, add K at the end, ie P1F-6032RNK
²⁾ -30 to +80°C

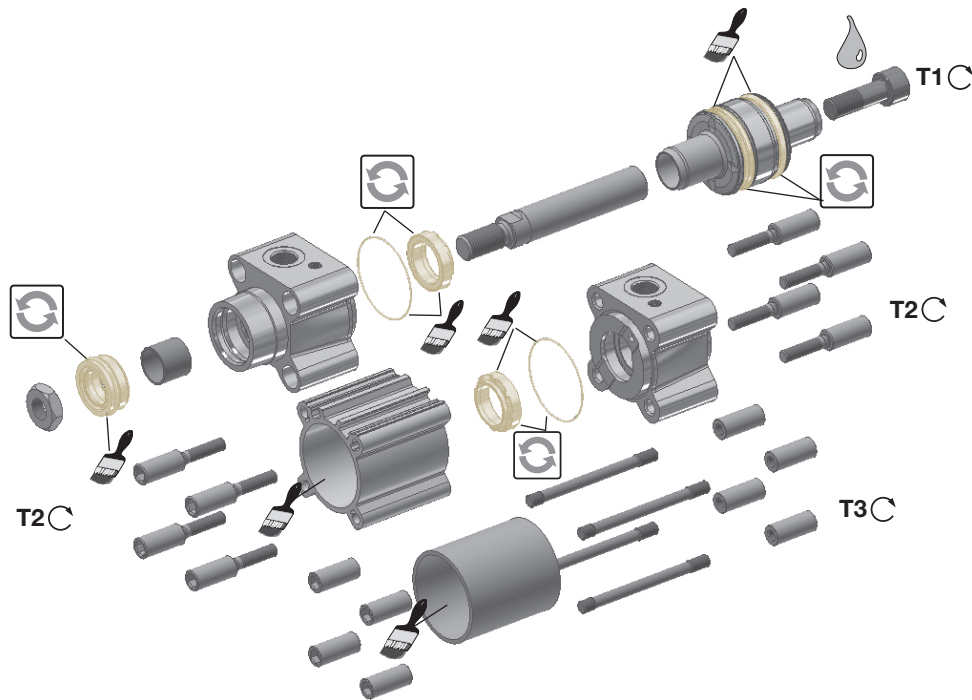

Bore size mm	Plastic piston T1 Nm	Al piston T1 Nm	AF mm	T2 Nm	AF mm	T3 Nm
32	4.5	15	6	11	6	4.5
40	11	30	8	11	6	4.5
50	20	40	10	18	8	9.5
63	20	40	10	18	8	9.5
80	40	120	14	29	6	19
100	120	120	14	29	6	19
125	120	120	14	70	8	40



= Included in seal kit



= Socket head across flats



= Tightening torque



Lubricated with grease



Locking fluid
 Loctite 270 or Loctite 2701 locking fluid must be used

Specifications

Specifying air quality (purity) in accordance with ISO8573-1:2010, the international standard for compressed air quality

ISO8573-1 is the primary document used from the ISO8573 series as it is this document which specifies the amount of contamination allowed in each cubic metre of compressed air.

ISO8573-1 lists the main contaminants as Solid Particulate, Water and Oil. The purity levels for each contaminant are shown separately in tabular form, however for ease of use, this document combines all three contaminants into one easy to use table.

ISO8573-1:2010 CLASS	Solid Particulate			Water		Oil	
	Maximum number of particles per m ³			Mass Concentration mg/m ³	Vapor Pressure Dewpoint	Liquid g/m ³	Total Oil (aerosol liquid and vapor) mg/m ³
	0,1 - 0,5 micron	0,5 - 1 micron	1 - 5 micron				
0	As specified by the equipment user or supplier and more stringent than Class 1						
1	≤ 20 000	≤ 400	≤ 10	-	≤ -70 °C	-	0,01
2	≤ 400 000	≤ 6 000	≤ 100	-	≤ -40 °C	-	0,1
3	-	≤ 90 000	≤ 1 000	-	≤ -20 °C	-	1
4	-	-	≤ 10 000	-	≤ +3 °C	-	5
5	-	-	≤ 100 000	-	≤ +7 °C	-	-
6	-	-	-	≤ 5	≤ +10 °C	-	-
7	-	-	-	5 - 10	-	≤ 0,5	-
8	-	-	-	-	-	0,5 - 5	-
9	-	-	-	-	-	5 - 10	-
X	-	-	-	> 10	-	> 10	> 10

Specifying air purity in accordance with ISO8573-1:2010

When specifying the purity of air required, the standard must always be referenced, followed by the purity class selected for each contaminant (a different purity class can be selected for each contamination if required).

An example of how to write an air quality specification is shown below:

ISO 8573-1:2010 Class 1.2.1

ISO 8573-1:2010 refers to the standard document and its revision, the three digits refer to the purity classifications selected for solid particulate, water and total oil. Selecting an air purity class of 1.2.1 would specify the following air quality when operating at the standard's reference conditions:

Class 1 - Particulate

In each cubic meter of compressed air, the particulate count should not exceed 20,000 particles in the 0.1 - 0.5 micron size range, 400 particles in the 0.5 - 1 micron size range and 10 particles in the 1 - 5 micron size range.

Class 2 - Water

A pressure dewpoint (PDP) of -40°C or better is required and no liquid water is allowed.

Class 1 - Oil

In each cubic meter of compressed air, not more than 0.01mg of oil is allowed. This is a total level for liquid oil, oil aerosol and oil vapor.

ISO8573-1:2010 Class zero

- Class 0 does not mean zero contamination.
- Class 0 requires the user and the equipment manufacturer to agree contamination levels as part of a written specification.
- The agreed contamination levels for a Class 0 specification should be within the measurement capabilities of the test equipment and test methods shown in ISO8573 Pt 2 to Pt 9.
- The agreed Class 0 specification must be written on all documentation to be in accordance with the standard.
- Stating Class 0 without the agreed specification is meaningless and not in accordance with the standard.
- A number of compressor manufacturers claim that the delivered air from their oil-free compressors is in compliance with Class 0.
- If the compressor was tested in clean room conditions, the contamination detected at the outlet will be minimal. Should the same compressor now be installed in typical urban environment, the level of contamination will be dependent upon what is drawn into the compressor intake, rendering the Class 0 claim invalid.
- A compressor delivering air to Class 0 will still require purification equipment in both the compressor room and at the point of use for the Class 0 purity to be maintained at the application.
- Air for critical applications such as breathing, medical, food, etc typically only requires air quality to Class 2.2.1 or Class 2.1.1.
- Purification of air to meet a Class 0 specification is only cost effective if carried out at the point of use.



For inventory, lead times, and kit lookup, visit www.pdnplu.com

PARKER-HANNIFIN CORPORATION
OFFER OF SALE

1. **Definitions.** As used herein, the following terms have the meanings indicated.

Buyer:	means any customer receiving a Quote for Products from Seller.
Goods:	means any tangible part, system or component to be supplied by the Seller.
Products:	means the Goods, Services and/or Software as described in a Quote provided by the Seller.
Quote:	means the offer or proposal made by Seller to Buyer for the supply of Products.
Seller:	means Parker-Hannifin Corporation, including all divisions and businesses thereof.
Services:	means any services to be supplied by the Seller.
Software:	means any software related to the Products, whether embedded or separately downloaded.
Terms:	means the terms and conditions of this Offer of Sale or any newer version of the same as published by Seller electronically at www.parker.com/saleterms .

2. **Terms.** All sales of Products by Seller are contingent upon, and will be governed by, these Terms and, these Terms are incorporated into any Quote provided by Seller to any Buyer. Buyer's order for any Products whether communicated to Seller verbally, in writing, by electronic data interface or other electronic commerce, shall constitute acceptance of these Terms. Seller objects to any contrary or additional terms or conditions of Buyer. Reference in Seller's order acknowledgement to Buyer's purchase order or purchase order number shall in no way constitute an acceptance of any of Buyer's terms of purchase. No modification to these Terms will be binding on Seller unless agreed to in writing and signed by an authorized representative of Seller.

3. **Price; Payment.** The Products set forth in Seller's Quote are offered for sale at the prices indicated in Seller's Quote. Unless otherwise specifically stated in Seller's Quote, prices are valid for thirty (30) days and do not include any sales, use, or other taxes or duties. Seller reserves the right to modify prices at any time to adjust for any raw material price fluctuations. Unless otherwise specified by Seller, all prices are F.C.A. Seller's facility (INCOTERMS 2010). All sales are contingent upon credit approval and payment for all purchases is due thirty (30) days from the date of invoice (or such date as may be specified in the Quote). Unpaid invoices beyond the specified payment date incur interest at the rate of 1.5% per month or the maximum allowable rate under applicable law.

4. **Shipment; Delivery; Title and Risk of Loss.** All delivery dates are approximate. Seller is not responsible for damages resulting from any delay. Regardless of the manner of shipment, delivery occurs and title and risk of loss or damage pass to Buyer, upon placement of the Products with the shipping carrier at Seller's facility. Unless otherwise agreed, Seller may exercise its judgment in choosing the carrier and means of delivery. No deferment of shipment at Buyers' request beyond the respective indicated shipping date will be made except on terms that will indemnify, defend and hold Seller harmless against all loss and additional expense. Buyer shall be responsible for any additional shipping charges incurred by Seller due to Buyer's acts or omissions.

5. **Warranty.** The warranty related to the Products is as follows: (i) Goods are warranted against defects in material or workmanship for a period of twelve (12) months from the date of delivery or 2,000 hours of use, whichever occurs first; (ii) Services shall be performed in accordance with generally accepted practices and using the degree of care and skill that is ordinarily exercised and customary in the field to which the Services pertain and are warranted for a period of six (6) months from the completion of the Services by Seller; and (iii) Software is only warranted to perform in accordance with applicable specifications provided by Seller to Buyer for ninety (90) days from the date of delivery or, when downloaded by a Buyer or end-user, from the date of the initial download. All prices are based upon the exclusive limited warranty stated above, and upon the following disclaimer:

DISCLAIMER OF WARRANTY: THIS WARRANTY IS THE SOLE AND ENTIRE WARRANTY PERTAINING TO PRODUCTS. SELLER DISCLAIMS ALL OTHER WARRANTIES, EXPRESS AND IMPLIED, INCLUDING DESIGN, NONINFRINGEMENT, MERCHANTABILITY, AND FITNESS FOR A PARTICULAR PURPOSE. SELLER DOES NOT WARRANT THAT THE SOFTWARE IS ERROR-FREE OR FAULT-TOLERANT, OR THAT BUYER'S USE THEREOF WILL BE SECURE OR UNINTERRUPTED. BUYER AGREES AND ACKNOWLEDGES THAT UNLESS OTHERWISE AUTHORIZED IN WRITING BY SELLER THE SOFTWARE SHALL NOT BE USED IN CONNECTION WITH HAZARDOUS OR HIGH RISK ACTIVITIES OR ENVIRONMENTS. EXCEPT AS EXPRESSLY STATED HEREIN, ALL PRODUCTS ARE PROVIDED "AS IS".

6. **Claims; Commencement of Actions.** Buyer shall promptly inspect all Products upon receipt. No claims for shortages will be allowed unless reported to the Seller within ten (10) days of delivery. Buyer shall notify Seller of any alleged breach of warranty within thirty (30) days after the date the non-conformance is or should have been discovered by Buyer. Any claim or action against Seller based upon breach of contract or any other theory, including tort, negligence, or otherwise must be commenced within twelve (12) months from the date of the alleged breach or other alleged event, without regard to the date of discovery.

7. **LIMITATION OF LIABILITY.** IN THE EVENT OF A BREACH OF WARRANTY, SELLER WILL, AT ITS OPTION, REPAIR OR REPLACE THE NON-CONFORMING PRODUCT, RE-PERFORM THE SERVICES, OR REFUND THE PURCHASE PRICE PAID WITHIN A REASONABLE PERIOD OF TIME. IN NO EVENT IS SELLER LIABLE FOR ANY SPECIAL, INDIRECT, INCIDENTAL OR CONSEQUENTIAL DAMAGES ARISING OUT OF, OR AS THE RESULT OF, THE SALE, DELIVERY, NON-DELIVERY, SERVICING, NON-COMPLETION OF SERVICES, USE, LOSS OF USE OF, OR INABILITY TO USE THE PRODUCTS OR ANY PART THEREOF, LOSS OF DATA, IDENTITY, PRIVACY, OR CONFIDENTIALITY, OR FOR ANY CHARGES OR EXPENSES OF ANY NATURE INCURRED WITHOUT SELLER'S WRITTEN CONSENT, WHETHER BASED IN CONTRACT, TORT OR OTHER LEGAL THEORY. IN NO EVENT SHALL SELLER'S LIABILITY UNDER ANY CLAIM MADE BY BUYER EXCEED THE PURCHASE PRICE PAID FOR THE PRODUCTS.

8. **Loss to Buyer's Property.** Any designs, tools, patterns, materials, drawings, confidential information or equipment furnished by Buyer or any other items which are or become Buyer's property, will be considered obsolete and may be destroyed by Seller after two (2) consecutive years have elapsed without Buyer ordering the Products manufactured using such property. Seller shall not be responsible for any loss or damage to such property while it is in Seller's possession or control.

9. **Special Tooling.** Special Tooling includes but is not limited to tooling, jigs, fixtures and associated manufacturing equipment acquired or necessary to manufacture Products. A tooling charge may be imposed for any Special Tooling. Such Special Tooling shall be and remain Seller's property notwithstanding payment of any charges by Buyer. In no event will Buyer acquire any interest in Special Tooling belonging to Seller that is utilized in the manufacture of the Products, even if such Special Tooling has been specially converted or adapted for such manufacture and notwithstanding any charges paid by Buyer. Unless otherwise agreed, Seller has the right to alter, discard or otherwise dispose of any Special Tooling or other property in its sole discretion at any time.

10. **Security Interest.** To secure payment of all sums due, Seller retains a security interest in all Products delivered to Buyer and, Buyer's acceptance of these Terms is deemed to be a Security Agreement under the Uniform Commercial Code. Buyer authorizes Seller as its attorney to execute and file on Buyer's behalf all documents Seller deems necessary to perfect its security interest.

11. **User Responsibility.** The Buyer through its own analysis and testing, is solely responsible for making the final selection of the Products and assuring that all performance, endurance, maintenance, safety and warning requirements of the application of the Products are met. The Buyer must analyze all aspects of the application and follow applicable industry standards, specifications, and other technical information provided with the Product. If Seller provides Product options based upon data or specifications provided by the Buyer, the Buyer is responsible for determining that such data and specifications are suitable and sufficient for all applications and reasonably foreseeable uses of the Products. In the event the Buyer is not the end-user, Buyer will ensure such end-user complies with this paragraph.

12. **Use of Products; Indemnity by Buyer.** Buyer shall comply with all instructions, guides and specifications provided by Seller with the Products. **Unauthorized Uses.** If Buyer uses or resells the Products for any uses prohibited in Seller's instructions, guides or specifications, or Buyer otherwise fails to comply with Seller's instructions, guides and specifications, Buyer acknowledges that any such use, resale, or non-compliance is at Buyer's sole risk. Buyer shall indemnify, defend, and hold Seller harmless from any losses, claims, liabilities, damages, lawsuits, judgments and costs (including attorney fees and defense costs), whether for personal injury, property damage, intellectual property infringement or any other claim, brought by or incurred by Buyer, Buyer's employees, or any other person, arising out of: (a) improper selection, application, design, specification or other misuse of Products provided by Seller; (b) any act or omission, negligent or otherwise, of Buyer; (c) Seller's use of patterns, tooling, equipment, plans, drawings, designs or specifications or other information or things furnished by Buyer; (d) damage to the Products from an external cause, repair or attempted repair by anyone other than Seller, failure to follow instructions, guides and specifications provided by Seller, use with goods not provided by Seller, or opening, modifying, deconstructing or tampering with the Products for any reason; or (e) Buyer's failure to comply with these Terms. Seller shall not indemnify Buyer under any circumstance except as otherwise provided in these Terms.

13. **Cancellations and Changes.** Buyer may not cancel or modify any order for any reason, except with Seller's written consent and upon terms that will indemnify, defend and hold Seller harmless against all direct, incidental and consequential loss or damage. Seller, at any time, may change Product features, specifications, designs and availability.

14. **Limitation on Assignment.** Buyer may not assign its rights or obligations without the prior written consent of Seller.

15. **Force Majeure.** Seller does not assume the risk and is not liable for delay or failure to perform any of Seller's obligations by reason of events or circumstances beyond its reasonable control ("Events of Force Majeure"). Events of Force Majeure shall include without limitation: accidents, strikes or labor disputes, acts of any government or government agency, acts of nature, delays or failures in delivery from carriers or suppliers, shortages of materials, or any other cause beyond Seller's reasonable control.

16. **Waiver and Severability.** Failure to enforce any provision of these Terms will not invalidate that provision; nor will any such failure prejudice Seller's right to enforce that provision in the future. Invalidation of any provision of these Terms by legislation or other rule of law shall not invalidate any other provision herein and, the remaining provisions will remain in full force and effect.

17. **Termination.** Seller may terminate any agreement governed by or arising from these Terms for any reason and at any time by giving Buyer thirty (30) days prior written notice. Seller may immediately terminate, in writing, if Buyer: (a) breaches any provision of these Terms (b) appoints a trustee, receiver or custodian for all or any part of Buyer's property (c) files a petition for relief in bankruptcy on its own behalf, or one if filed by a third party (d) makes an assignment for the benefit of creditors; or (e) dissolves its business or liquidates all or a majority of its assets.

18. **Ownership of Software.** Seller retains ownership of all Software supplied to Buyer hereunder. In no event shall Buyer obtain any greater right in and to the Software than a right in the nature of a license limited to the use thereof and subject to compliance with any other terms provided with the Software.

19. **Indemnity for Infringement of Intellectual Property Rights.** Seller is not liable for infringement of any patents, trademarks, copyrights, trade dress, trade secrets or similar rights ("Intellectual Property Rights") except as provided in this Section. Seller will defend at its expense and will pay the cost of any settlement or damages awarded in an action brought against Buyer based on a third party claim that one or more of the Products sold hereunder infringes the Intellectual Property Rights of a third party in the country of delivery of the Products by the Seller to the Buyer. Seller's obligation to defend and indemnify Buyer is contingent on Buyer notifying Seller within ten (10) days after Buyer becomes aware of any such claim, and Seller having sole control over the defense of the claim including all negotiations for settlement or compromise. If one or more Products sold hereunder is subject to such a claim, Seller may, at its sole expense and option, procure for Buyer the right to continue using the Products, replace or modify the Products so as to render them non-infringing, or offer to accept return of the Products and refund the purchase price less a reasonable allowance for depreciation. Seller has no obligation or liability for any claim of infringement: (i) arising from information provided by Buyer; or (ii) directed to any Products provided hereunder for which the designs are specified in whole or part by Buyer; or (iii) resulting from the modification, combination or use in a system of any Products provided hereunder. The foregoing provisions of this Section constitute Seller's sole and exclusive liability and Buyer's sole and exclusive remedy for such claims of infringement of Intellectual Property Rights.

20. **Governing Law.** These Terms and the sale and delivery of all Products are deemed to have taken place in, and shall be governed and construed in accordance with, the laws of the State of Ohio, as applicable to contracts executed and wholly performed therein and without regard to conflicts of laws principles. Buyer irrevocably agrees and consents to the exclusive jurisdiction and venue of the courts of Cuyahoga County, Ohio with respect to any dispute, controversy or claim arising out of or relating to the sale and delivery of the Products.

21. **Entire Agreement.** These Terms, along with the terms set forth in the main body of any Quote, forms the entire agreement between the Buyer and Seller and constitutes the final, complete and exclusive expression of the terms of sale. In the event of a conflict between any term set forth in the main body of a Quote and these Terms, the terms set forth in the main body of the Quote shall prevail. All prior or contemporaneous written or oral agreements or negotiations with respect to the subject matter shall have no effect. These Terms may not be modified unless in writing and signed by an authorized representative of Seller.

22. **Compliance with Laws.** Buyer agrees to comply with all applicable laws, regulations, and industry and professional standards, including those of the United States of America, and the country or countries in which Buyer may operate, including without limitation the U.S. Foreign Corrupt Practices Act ("FCPA"), the U.S. Anti-Kickback Act ("Anti-Kickback Act"), U.S. and E.U. export control and sanctions laws ("Export Laws"), the U.S. Food Drug and Cosmetic Act ("FDCA"), and the rules and regulations promulgated by the U.S. Food and Drug Administration ("FDA"), each as currently amended. Buyer agrees to indemnify, defend, and hold harmless Seller from the consequences of any violation of such laws, regulations and standards by Buyer, its employees or agents. Buyer acknowledges that it is familiar with all applicable provisions of the FCPA, the Anti-Kickback Act, Export Laws, the FDCA and the FDA and certifies that Buyer will adhere to the requirements thereof and not take any action that would make Seller violate such requirements. Buyer represents and agrees that Buyer will not make any payment or give anything of value, directly or indirectly, to any governmental official, foreign political party or official thereof, candidate for foreign political office, or commercial entity or person, for any improper purpose, including the purpose of influencing such person to purchase Products or otherwise benefit the business of Seller. Buyer further represents and agrees that it will not receive, use, service, transfer or ship any Product from Seller in a manner or for a purpose that violates Export Laws or would cause Seller to be in violation of Export Laws.

Parker Worldwide

Europe, Middle East, Africa

AE – United Arab Emirates, Dubai
Tel: +971 4 8127100
parker.me@parker.com

AT – Austria, Wiener Neustadt
Tel: +43 (0)2622 23501-0
parker.austria@parker.com

AT – Eastern Europe, Wiener Neustadt
Tel: +43 (0)2622 23501 900
parker.easteurope@parker.com

AZ – Azerbaijan, Baku
Tel: +994 50 2233 458
parker.azerbaijan@parker.com

BE/LU – Belgium, Nivelles
Tel: +32 (0)67 280 900
parker.belgium@parker.com

BG – Bulgaria, Sofia
Tel: +359 2 980 1344
parker.bulgaria@parker.com

BY – Belarus, Minsk
Tel: +48 (0)22 573 24 00
parker.poland@parker.com

CH – Switzerland, Etoy
Tel: +41 (0)21 821 87 00
parker.switzerland@parker.com

CZ – Czech Republic, Klecany
Tel: +420 284 083 111
parker.czechrepublic@parker.com

DE – Germany, Kaarst
Tel: +49 (0)2131 4016 0
parker.germany@parker.com

DK – Denmark, Ballerup
Tel: +45 43 56 04 00
parker.denmark@parker.com

ES – Spain, Madrid
Tel: +34 902 330 001
parker.spain@parker.com

FI – Finland, Vantaa
Tel: +358 (0)20 753 2500
parker.finland@parker.com

FR – France, Contamine s/Arve
Tel: +33 (0)4 50 25 80 25
parker.france@parker.com

GR – Greece, Athens
Tel: +30 210 933 6450
parker.greece@parker.com

HU – Hungary, Budaörs
Tel: +36 23 885 470
parker.hungary@parker.com

IE – Ireland, Dublin
Tel: +353 (0)1 466 6370
parker.ireland@parker.com

IL – Israel
Tel: +39 02 45 19 21
parker.israel@parker.com

IT – Italy, Corsico (MI)
Tel: +39 02 45 19 21
parker.italy@parker.com

KZ – Kazakhstan, Almaty
Tel: +7 7273 561 000
parker.easteurope@parker.com

NL – The Netherlands, Oldenzaal
Tel: +31 (0)541 585 000
parker.nl@parker.com

NO – Norway, Asker
Tel: +47 66 75 34 00
parker.norway@parker.com

PL – Poland, Warsaw
Tel: +48 (0)22 573 24 00
parker.poland@parker.com

PT – Portugal
Tel: +351 22 999 7360
parker.portugal@parker.com

RO – Romania, Bucharest
Tel: +40 21 252 1382
parker.romania@parker.com

RU – Russia, Moscow
Tel: +7 495 645-2156
parker.russia@parker.com

SE – Sweden, Spånga
Tel: +46 (0)8 59 79 50 00
parker.sweden@parker.com

SL – Slovenia, Novo Mesto
Tel: +386 7 337 6650
parker.slovenia@parker.com

TR – Turkey, Istanbul
Tel: +90 216 4997081
parker.turkey@parker.com

UA – Ukraine, Kiev
Tel: +48 (0)22 573 24 00
parker.poland@parker.com

UK – United Kingdom, Warwick
Tel: +44 (0)1926 317 878
parker.uk@parker.com

ZA – South Africa, Kempton Park
Tel: +27 (0)11 961 0700
parker.southafrica@parker.com

North America

CA – Canada, Milton, Ontario
Tel: +1 905 693 3000
www.parker.com/canada

US – USA, Cleveland
Tel: +1 216 896 3000

Asia Pacific

AU – Australia, Castle Hill
Tel: +61 (0)2-9634 7777

CN – China, Shanghai
Tel: +86 21 2899 5000

HK – Hong Kong
Tel: +852 2428 8008

IN – India, Mumbai
Tel: +91 22 6513 7081-85

JP – Japan, Tokyo
Tel: +81 (0)3 6408 3901

KR – South Korea, Seoul
Tel: +82 2 559 0400

MY – Malaysia, Shah Alam
Tel: +60 3 7849 0800

NZ – New Zealand, Mt Wellington
Tel: +64 9 574 1744

SG – Singapore
Tel: +65 6887 6300

TH – Thailand, Bangkok
Tel: +662 186 7000

TW – Taiwan, Taipei
Tel: +886 2 2298 8987

South America

AR – Argentina, Buenos Aires
Tel: +54 3327 44 4129

BR – Brazil, Sao Jose dos Campos
Tel: +55 800 727 5374

CL – Chile, Santiago
Tel: +56 2 623 1216

MX – Mexico, Toluca
Tel: +52 72 2275 4200

European Product Information Centre
Free phone: 00 800 27 27 5374
(from AT, BE, CH, CZ, DE, DK, EE, ES, FI,
FR, IE, IL, IS, IT, LU, MT, NL, NO, PL, PT,
RU, SE, SK, UK, ZA)



Parker Hannifin Corporation

Pneumatic Division

135 Quadral Drive

Wadsworth, OH 44281 USA

Phone: (269) 629-5575

Applications Engineering: pdnapps@parker.com

Customer Support: pdncustsvc@parker.com